



“Big Red”

T-450S / T-520S

**Taylor Industrial Trucks
Standard Specifications**

T-450S Rated Capacity 45,000-lbs. **(20,412 kg)**

T-520S Rated Capacity 52,000-lbs. **(23,587 kg)**

36-in. **(914 mm)** Load Center

130-in. **(3,302 mm)** Wheelbase

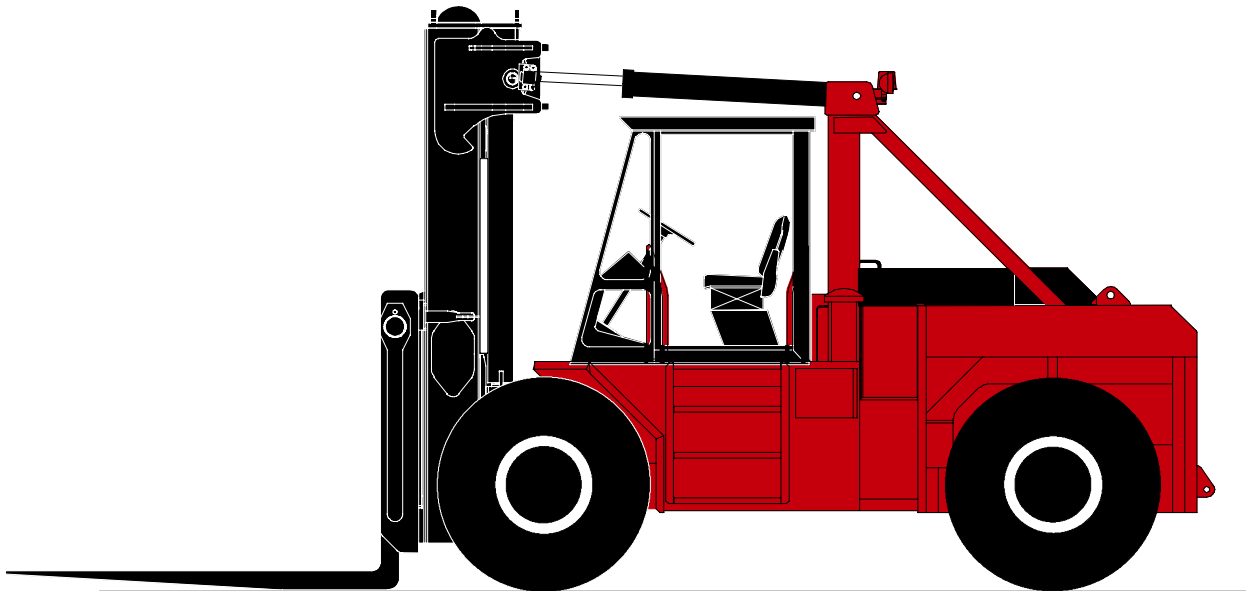

“Big Red” T-450S / T-520S

| GENERAL | 1 | Manufacturer | Manufacturer's Name | TAYLOR | | TAYLOR | | |
|--------------------|---------------|---|--|---------------------------------------|-----------------------|--------------|-----------------------|-------------|
| | 2 | Model | Manufacturer's Designation | T-450S | | T-520S | | |
| | | | | English | Metric | English | Metric | |
| | 3 | Capacity | Rated Capacity | lb (kg) | 45,000 | 20,412 | 52,000 | 23,587 |
| | 4 | Load Center | Distance | in (mm) | 36 | 914 | 36 | 914 |
| | 5 | Power Type | Gas, LPG, Or Diesel | | Diesel | | Diesel | |
| | 6 | Tire Type | Cushion, Pneumatic Front / Rear | | Pneumatic / Pneumatic | | Pneumatic / Pneumatic | |
| | 7 | Wheels | Number (X = Driven) Front / Rear | | 4X / 2 | | 4X / 2 | |
| DIMENSIONS | 8 | Upright Lift | Standard Lift (Top Of Fork) | in (mm) | 136.5 | 3,467 | 137 | 3,480 |
| | 9 | Forks | Thickness | in (mm) | 4.5 | 114 | 5 | 127 |
| | 9A | | Width | in (mm) | 8.5 | 216 | 10 | 254 |
| | 9B | | Length | in (mm) | 72 | 1,829 | 72 | 1,829 |
| | 10 | | Tilt Angle | Standard Upright - Forward / Backward | deg.° | 15 / 10 | | 15 / 10 |
| | 11 | Overall Dimensions | Length To Face Of Forks | in (mm) | 211 | 5,359 | 212.25 | 5,391 |
| | 12 | | Width (Standard Tires) | in (mm) | 120 | 3,048 | 120 | 3,048 |
| | 13 | | Height, Standard Upright Lowered | in (mm) | 155 | 3,937 | 155 | 3,937 |
| | 14 | | Height, Standard Upright Extended | in (mm) | 221 | 5,613 | 221 | 5,613 |
| | 15 | | Height To Top Of Counterweight | in (mm) | 72 | 1,829 | 72 | 1,829 |
| | 16 | Turning Radius | Height To Top Of A-Frame | in (mm) | 129 | 3,277 | 129 | 3,277 |
| | 17 | | Minimum Outside | in (mm) | 198 | 5,029 | 198 | 5,029 |
| | 17A | Minimum Inside | in (mm) | 15 | 381 | 15 | 381 | |
| 18 | Load Distance | Center Of Wheel To Face Of Forks | in (mm) | 40.75 | 1,035 | 42.25 | 1,073 | |
| 19 | Aisle Width | (Add Load Length For 90° Stacking) | in (mm) | 238.75 | 6,064 | 240.25 | 6,102 | |
| PERFORMANCE | 20 | Stability | Comply With ANSI? | | Yes | | Yes | |
| | 21 | Speeds | Travel Speed - Maximum Forward | mph (km/h) | 15.7 | 25.3 | 15.7 | 25.3 |
| | 22 | | Lift Speed - No Load | fpm (m/s) | 56 | 0.28 | 56 | 0.28 |
| | 22A | | Lift Speed - With Load | fpm (m/s) | 49 | 0.25 | 49 | 0.25 |
| | 23 | | Lowering Speed - No Load / With Load | fpm (m/s) | 60 | .3 | 60 | .3 |
| | 24 | Drawbar Pull | Powershift (Maximum At Stall) | lb (kN) | 35,425 | 158 | 35,300 | 157 |
| 25 | Gradeability | Powershift (Maximum At Stall) No Load | % | 26 | | 30.2 | | |
| 25A | | Powershift (Maximum At Stall) With Load | % | 32 | | 28.4 | | |
| WEIGHT | 26 | Ttl. Apprx. Wt. | Standard Truck | lb (kg) | 67,200 | 30,482 | 73,700 | 33,430 |
| | 27 | Axle Loading | Static With Rated Load - Front | lb (kg) | 100,740 | 45,696 | 112,290 | 50,935 |
| | 27A | | Static With Rated Load - Rear | lb (kg) | 11,460 | 5,198 | 13,410 | 6,083 |
| | 27B | | Static With No Load - Front | lb (kg) | 29,000 | 13,154 | 29,000 | 13,154 |
| | 27C | | Static With No Load - Rear | lb (kg) | 38,200 | 17,328 | 44,700 | 20,276 |
| WHEELS / TIRES | 28 | Tires | Number - Front / Rear | | 4 / 2 | | 4 / 2 | |
| | 29 | | Size - Front | | 14.00 x 25 - 20 PR | | 14.00 x 25 - 20 PR | |
| | 30 | | Size - Rear | | 14.00 x 25 - 20 PR | | 14.00 x 25 - 20 PR | |
| | 31 | Wheelbase | Distance | in (mm) | 130 | 3,302 | 130 | 3,302 |
| | 32 | Tread | Center Of Outside (Dual) Tires - Front | in (mm) | 104.5 | 2,654 | 104.5 | 2,654 |
| | 32A | | Center Of Tires - Rear | in (mm) | 91 | 2,311 | 91 | 2,311 |
| | 33 | Ground Clearance | No Load At Lowest Point | in (mm) | 12 | 305 | 12 | 305 |
| | 34 | | No Load At Center Of Wheelbase | in (mm) | 18 | 457 | 18 | 457 |
| 35 | Brakes | Service / Parking - Method Of Control | | Foot / Hand | | Foot / Hand | | |
| 36 | | Service / Parking - Method Of Operation | | Air / Spring | | Air / Spring | | |
| POWER UNITS / XMSN | 37 | Battery | Volts / Ampere Hours (2 Batteries) | V/Ah | 12 / 2300 | | 12 / 2300 | |
| | 38 | Internal Combustion Engine | Make / Model | | Cummins QSC8.3-C230 | | Cummins QSC8.3-C230 | |
| | 39 | | Output - Intermittent Per SAE Standards | hp (kW) | 230 | 172 | 230 | 172 |
| | 40 | | Governed Speed - With Load | rpm | 2200 | | 2200 | |
| | 41 | | Cycle / Number Of Cylinders / Displacement | cu-in (L) | 4 / 6 / 506 | 4 / 6 / 8.3 | 4 / 6 / 506 | 4 / 6 / 8.3 |
| | 42 | Clutch | Type | | Declutch | | Declutch | |
| | 43 | Gear Change | Type | | Hand | | Hand | |
| | 44 | Transmission | Number Of Speeds - Forward / Reverse | | 3 / 3 | | 3 / 3 | |
| | 45 | | Type | | Powershift | | Powershift | |
| | 46 | Relief Press. | For Attachments | psi (bar) | 1500 | 103 | 1500 | 103 |
| 47 | | Width Across Counterweight | in (mm) | 108 | 2,743 | 108 | 2,743 | |
| 48 | | Standard Fork Spread | in (mm) | 100 | 2,540 | 100 | 2,540 | |
| 49 | | Ground To Top Of Carriage | in (mm) | 76.5 | 1,943 | 79 | 2,007 | |
| 50 | | Load Moment | in-lbs (m-kg) | 3,453,750 | 39,792 | 4,069,000 | 46,881 | |

† NOTE: Performance specifications are for trucks equipped as described on the back page of this specification sheet. Performance specifications are affected by the condition of the vehicle, its components, and the nature and condition of the operating area. If these specifications are critical, the proposed application should be discussed with your Taylor sales representative.

“Big Red” T-450S / T-520S

| Mast Dimensions (inches / millimeters) | | Optional Lift Height (8) | | | | OAHL (13) | | OAHR (14) | |
|--|---------|--------------------------|---------|--------|---------|-----------|---------|-----------|--|
| 2-Stage ULTRA-VU Telescopic Mast | T-450S | | T-520S | | | | | | |
| | English | Metric | English | Metric | English | Metric | English | Metric | |
| | 136.5 | 3,467 | 137 | 3,480 | 155 | 3,937 | 221 | 5,613 | |
| | 160.5 | 4,077 | 161 | 4,089 | 167 | 4,242 | 245 | 6,223 | |
| | 184.5 | 4,686 | 185 | 4,699 | 179 | 4,547 | 269 | 6,833 | |
| 220.5 | 5,601 | 221 | 5,613 | 197 | 5,004 | 305 | 7,747 | | |

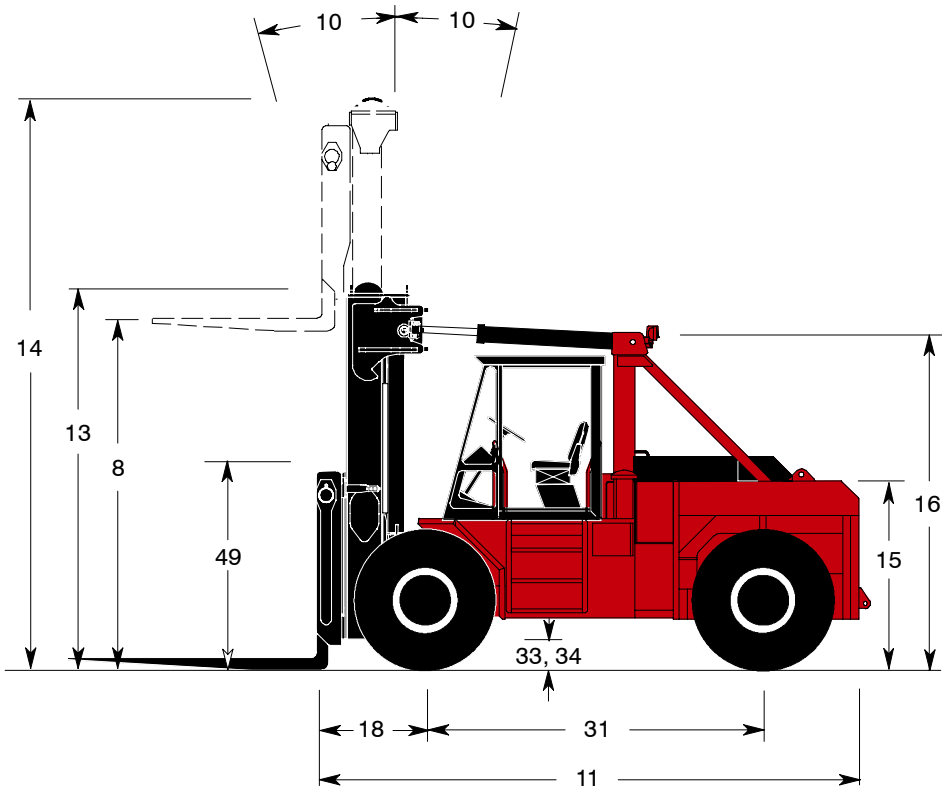
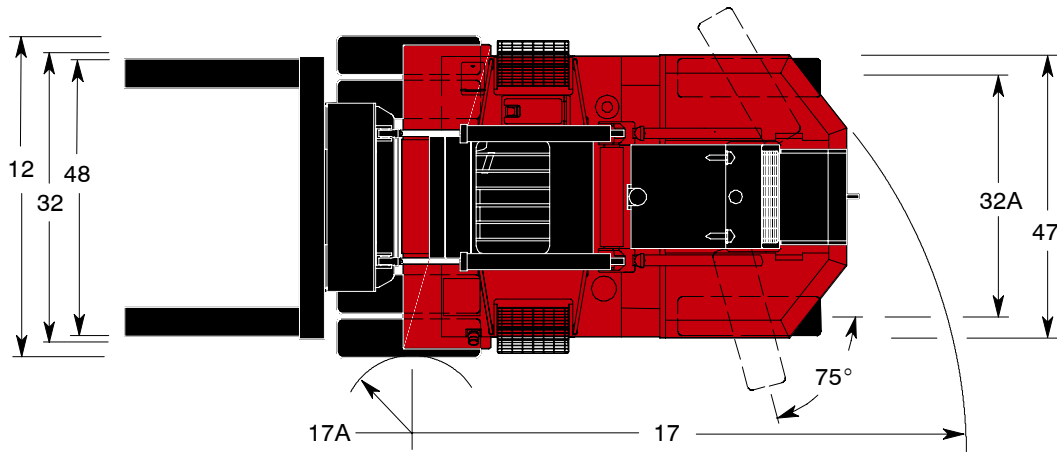

“Big Red” T-450S / T-520S

Engine

Cummins QSC8.3-C230, 6-cylinder electronic turbocharged, charge air after cooled (air to air) diesel engine has 506 cu-in. (8.3 L) displacement, 4.49-in. (114 mm) bore x 5.31-in. (135 mm) stroke. Rated power 230-hp (172 kW) at 2200 rpm (all engine ratings are based on SAE standard ambient conditions). Maximum power of 250-hp (186 kW) at 2000 rpm. Peak torque is 800 ft-lbs. (1,085 N-m) at 1500 rpm. Emission certification: US EPA Tier III, Carb Tier III, EU Stage III. Standard features are electronic diagnostic, maintenance monitor, fuel/water separator, engine/transmission protection system, fuel economy and reduced emissions.

Fuel tank capacity is 60 gallons (227 L).

Air Cleaner

The dry air cleaner has a safety element and restriction indicator.

Cooling System

The coolant recovery cooling system has an extra large, down flow radiator for maximum efficiency. The wide fin spacing reduces dirt build-up and provides optimum engine cooling.

Electrical, Instrumentation, and Accessories

The one-piece instrument panel flips down for easy servicing and is pre-wired to accommodate heavy-duty accessories. All wiring is color coded.

The unit has a 12-volt electrical system. Standard equipment includes a key-type anti-restart ignition system, 2 heavy-duty batteries, 100-amp alternator, mechanical pressure gauges, electrical temperature gauges, reset circuit breakers, lighted instruments, horn, key-switch actuated amber strobe light, reverse-actuated warning alarm and tilt steering.

Gauges include fuel level, ammeter, hourmeter, air pressure, engine oil pressure, engine coolant temperature, transmission oil pressure, and transmission oil temperature. Lights included are seat belt light, low air light, parking brake light, and step lights.

Transmission

The three-speed, fully reversing, modulated, powershift transmission has declutch and electric shift control. Brakes behind declutch. The filler pipe dipstick and large, heavy-duty oil filter are easily accessible. Separate air-to-oil cooler. The integrally built torque converter has constant-mesh gear sets actuated by hydraulic clutch packs. An automatic powershift control is standard.

Drive Axle

The heavy-duty planetary type housing is welded to the frame; the axle utilizes a hypoid ring gear and pinion.

Steer Axle

The single hydraulic cylinder design steer axle, with heavy-duty links from the cylinder ram directly to tapered roller bearing mounted spindles, has tapered wheel and kingpin bearings. All joints are sealed, can be lubricated, and never need adjusting.

Brake System

The force cooled, wet disc, air/hydraulic actuated, service brakes are mounted on the drive axle. The transmission is equipped with a spring applied drum brake for parking.

Chassis

The all welded frame has an integral, sloped, counterweight and tubular A-frame. A spring-assisted hood and hinged doors provide easy access to service points.

The canopy is integral with the operator station base. The center mount operator station is standard and can be optionally located offset to the left side of the vehicle. The tinted, unbreakable, Lexan top with steel crossbars provides maximum visibility and protection. The suspension seat with an operator seat belt is adjustable.

Hydraulic System

The large capacity hydraulic tank has a spin-on tank breather, suction strainers, return line filters and replaceable elements in the tank. The hydraulic system utilizes transmission-driven gear type pumps. The tank refill capacity is 72 gallons (273 L). The tilt lock valve prevents mast drift and reduces torsional stress. Dual lift cylinders have chrome-plated rods and self-adjusting packing. Control levers are conveniently located. Valves are controlled with hydraulic remotes.

Mast, Carriage, and Rollers

The 11-ft. (3.4 m) ULTRA-VU telescopic, nested-channel mast, with two nested, hidden multiple-leaf lift chains, is constructed of high-strength steel for minimal weight. The two lifting eyes and bolt-on caps permit safe, easy removal of the mast.

The 100-in. (2,540 mm) “C” type carriage is high strength-to-weight ratio. The forks are pin-mounted and fully adjustable from 100-in. (2,540 mm) outside to 2-in. (51 mm) inside the center brace.

Main rollers and chain rollers have shielded, tapered, roller bearings. The carriage side wear pads are adjustable to compensate for wear. All rollers can be lubricated.

Forks

The forks are hammer forged from heat treated alloy steel.

Size for T-450S:

4.5-in. x 8.5-in. x 72-in. (114 mm x 216 mm x 1,829 mm)

Size for T-520S:

5-in. x 10-in. x 72-in. (127 mm x 254 mm x 1,829 mm)

This vehicle is certified to meet the applicable design and performance criteria required for Powered Industrial Trucks in OSHA Safety and Health Standards, Title 29 CFR, Part 1910.178, and the applicable design and performance requirements in ANSI B56.1 that were in effect at the time of manufacture. These standards also apply to the user and should be adhered to while operating this vehicle.

All specifications are subject to change without notice. Some operating data may be affected by the condition of the operating area. If these specifications are critical, contact the factory.