



“Big Red” THC-250S / THC-300S

Taylor Cushion Tire Industrial Trucks Standard Specifications

THC-250S

Rated Capacity 25,000-lbs. (11,340 kg)

24-in. (610 mm) Load Center

94-in. (2,388 mm) Wheelbase

THC-300S

Rated Capacity 30,000-lbs. (13,608 kg)

24-in. (610 mm) Load Center

94-in. (2,388 mm) Wheelbase

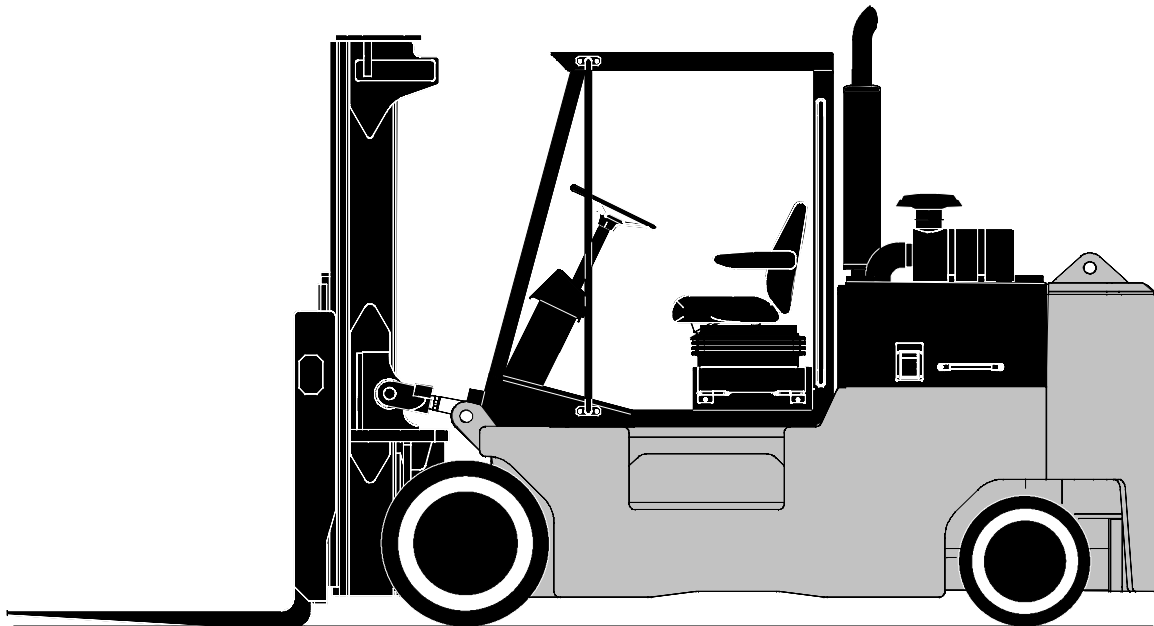

"Big Red" THC-250S / THC-300S

| GENERAL | 1 | Manufacturer | Manufacturer's Name | TAYLOR | | TAYLOR | | | |
|--------------------|--------------|-----------------------------------------|--------------------------------------------|--------------------------------|------------------------|-------------|-------------------|-------------|------|
| | 2 | Model | Manufacturer's Designation | THC-250S | | THC-300S | | | |
| | | | | English | Metric | English | Metric | | |
| | 3 | Capacity | Rated Capacity | lb (kg) | 25,000 | 11,340 | 30,000 | 13,608 | |
| | 4 | Load Center | Distance | in (mm) | 24 | 610 | 24 | 610 | |
| | 5 | Power Type | Gas, LPG, Or Diesel | | Diesel | | Diesel | | |
| | 6 | Tire Type | Cushion, Pneumatic Front / Rear | | Cushion / Cushion | | Cushion / Cushion | | |
| | 7 | Wheels | Number (X = Driven) Front / Rear | | 2X / 2 | | 2X / 2 | | |
| DIMENSIONS | 8 | Upright Lift | Standard Lift (Top Of Fork) | in (mm) | 99 | 2,515 | 99 | 2,515 | |
| | 8A | | Free Lift | in (mm) | 40 | 1,016 | 40 | 1,016 | |
| | 9 | Forks | Thickness | in (mm) | 3 | 76.2 | 3 | 76.2 | |
| | 9A | | Width | in (mm) | 8 | 203.2 | 8 | 203.2 | |
| | 9B | | Length | in (mm) | 48 | 1,219.2 | 48 | 1,219.2 | |
| | 10 | Tilt Angle | Standard Upright - Forward / Backward | deg.° | 10 / 10 | | 10 / 10 | | |
| | 11 | Overall Dimensions | Length To Face Of Forks | in (mm) | 144.625 | 3,673.5 | 144.625 | 3,673.5 | |
| | 12 | | Width (Standard Tires) | in (mm) | 62 | 1,574.8 | 62 | 1,574.8 | |
| | 13 | | Height, Standard Upright Lowered | in (mm) | 100 | 2,540 | 100 | 2,540 | |
| | 14 | | Height, Standard Upright Extended | in (mm) | 156 | 3,962.4 | 156 | 3,962.4 | |
| | 15 | | Height To Top Of Counterweight | in (mm) | 58 | 1,473.2 | 58 | 1,473.2 | |
| | 16 | Turning Radius | Height To Top Of Overhead Guard | in (mm) | 96.9 | 2,461.3 | 96.9 | 2,461.3 | |
| | 17 | | Minimum Outside | in (mm) | 132 | 3,352.8 | 132 | 3,352.8 | |
| | 17A | | Minimum Inside | in (mm) | 13 | 330.2 | 13 | 330.2 | |
| | 18 | Load Distance | Center Of Wheel To Face Of Forks | in (mm) | 28.625 | 727 | 28.625 | 727 | |
| | 19 | Aisle Width | (Add Load Length For 90° Stacking) | in (mm) | 160.625 | 4,080 | 160.625 | 4,080 | |
| | PERFORMANCE | 20 | Stability | Comply With ANSI? | | Yes | | Yes | |
| | | 21 | Speeds | Travel Speed - Maximum Forward | mph (km/h) | 9.8 | 15.8 | 9.7 | 15.6 |
| | | 22 | | Lift Speed - No Load | fpm (m/s) | - | - | - | - |
| 22A | | Lift Speed - With Load | | fpm (m/s) | - | - | - | - | |
| 23 | | Lowering Speed - No Load / With Load | | fpm (m/s) | - | - | - | - | |
| 24 | | Drawbar Pull | Powershift (Maximum At Stall) | lb (kN) | 28,700 | 127.7 | 28,700 | 127.7 | |
| 25 | Gradeability | Powershift (Maximum At Stall) No Load | % | 27.8 | | 27.2 | | | |
| 25A | | Powershift (Maximum At Stall) With Load | % | 58.2 | | 52.5 | | | |
| WEIGHT | 26 | Ttl. Apprx. Wt. | Standard Truck | lb (kg) | 38,750 | 17,577 | 42,500 | 19,278 | |
| | 27 | Axle Loading | Static With Rated Load - Front | lb (kg) | 59,000 | 26,762 | 67,000 | 30,391 | |
| | 27A | | Static With Rated Load - Rear | lb (kg) | 4,750 | 2,155 | 5,500 | 2,495 | |
| | 27B | | Static With No Load - Front | lb (kg) | 20,000 | 9,072 | 20,000 | 9,072 | |
| | 27C | | Static With No Load - Rear | lb (kg) | 18,750 | 8,505 | 22,500 | 10,206 | |
| WHEELS / TIRES | 28 | Tires | Number - Front / Rear | | 2 / 2 | | 2 / 2 | | |
| | 29 | | Size - Front | | 28 x 16 x 22 Poly | | 28 x 16 x 22 Poly | | |
| | 30 | | Size - Rear | | 22 x 9 x 16 Poly | | 22 x 10 x 16 Poly | | |
| | 31 | Wheelbase | Distance | in (mm) | 94 | 2,388 | 94 | 2,388 | |
| | 32 | Tread | Center Of Tires - Front | in (mm) | 46 | 1,168.4 | 46 | 1,168.4 | |
| | 32A | | Center Of Tires - Rear | in (mm) | 50 | 1,270 | 50 | 1,270 | |
| | 33 | Ground Clearance | No Load At Lowest Point | in (mm) | 5 | 127 | 5 | 127 | |
| | 34 | | No Load At Center Of Wheelbase | in (mm) | 6 | 152.4 | 6 | 152.4 | |
| | 35 | Brakes | Service / Parking - Method Of Control | | Foot / Hand | | Foot / Hand | | |
| | 36 | | Service / Parking - Method Of Operation | | Air / Air | | Air / Air | | |
| POWER UNITS / XMSN | 37 | Battery | Volts / Ampere Hours (1 Battery) | V/Ah | 12 / 1000 | | 12 / 1000 | | |
| | 38 | Internal Combustion Engine | Make / Model | | Cummins QSB5.9-30-C155 | | Cummins B5.9-C155 | | |
| | 39 | | Output - Intermittent Per SAE Standards | hp (kW) | 155 | 116 | 155 | 116 | |
| | 40 | | Governed Speed - With Load | rpm | 2000 | | 2000 | | |
| | 41 | | Cycle / Number Of Cylinders / Displacement | cu-in (L) | 4 / 6 / 359 | 4 / 6 / 5.9 | 4 / 6 / 359 | 4 / 6 / 5.9 | |
| | 42 | Clutch | Type | | Inching | | Inching | | |
| | 43 | Gear Change | Type | | Hand | | Hand | | |
| | 44 | Transmission | Number Of Speeds - Forward / Reverse | | 3 / 3 | | 3 / 3 | | |
| | 45 | | Type | | Powershift | | Powershift | | |
| | 46 | Relief Press. | For Attachments | psi (bar) | 1500 | 103.4 | 1500 | 103.4 | |
| 47 | | Width Across Counterweight | in (mm) | 62 | 1,575 | 62 | 1,575 | | |
| 48 | | Standard Fork Spread | in (mm) | 58 | 1,473 | 58 | 1,473 | | |
| 49 | | Ground To Top Of Carriage | in (mm) | 53.5 | 1358.9 | 53.5 | 1358.9 | | |
| 50 | | Load Moment | in-lbs (m-kg) | 1,315,625 | 15,158 | 1,578,600 | 18,188 | | |

† NOTE: Performance specifications are for trucks equipped as described on the back page of this specification sheet. Performance specifications are affected by the condition of the vehicle, its components, and the nature and condition of the operating area. If these specifications are critical, the proposed application should be discussed with your Taylor sales representative.

"Big Red" THC-250S / THC-300S

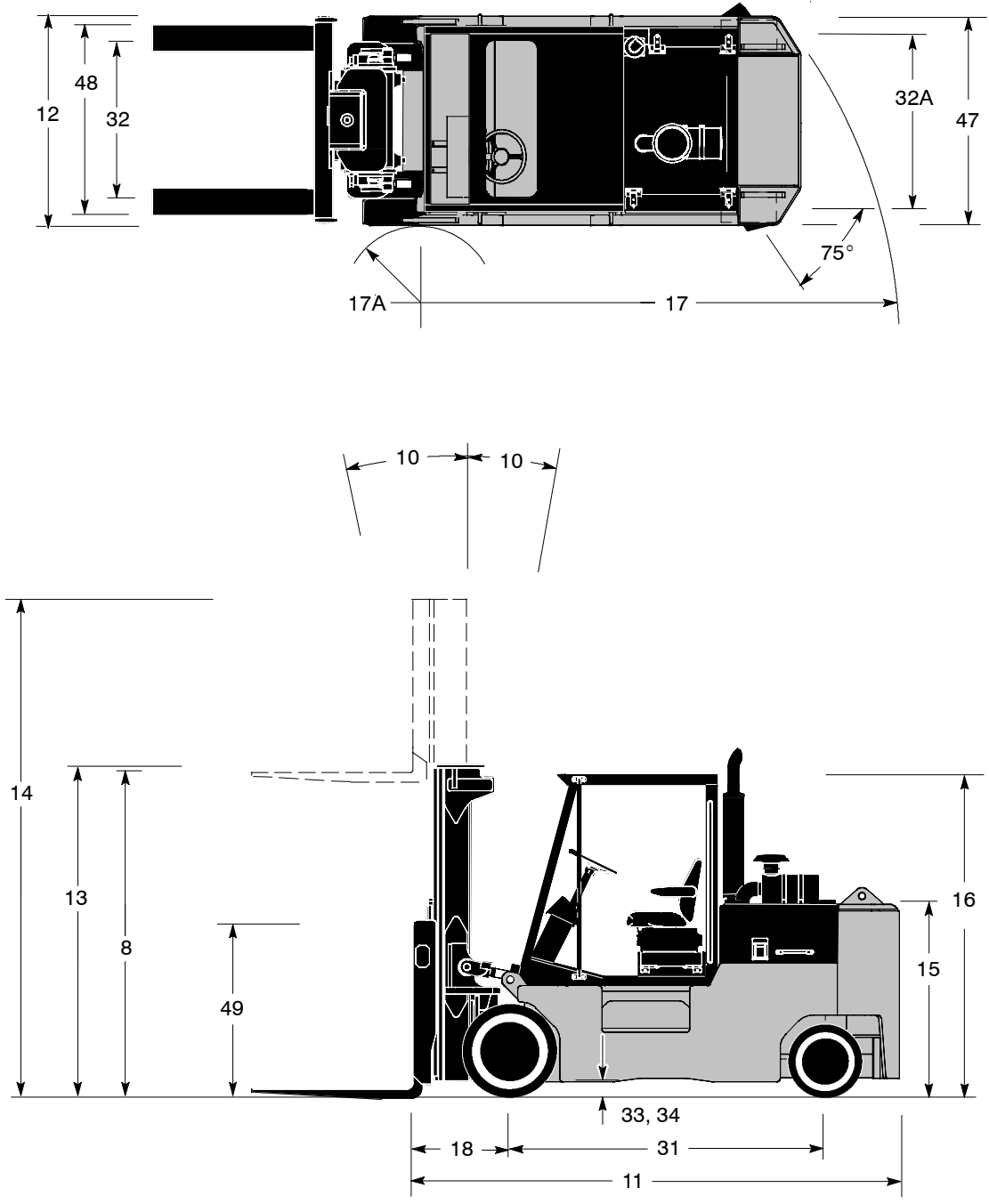

“Big Red” THC-250S / THC-300S

Engine

Cummins QSB5.9-30-C155 electronic turbocharged diesel, 6-cylinder diesel engine has 359 cu-in. (5.9 L) displacement. 4.02-in. (102 mm) bore x 4.72-in. (120 mm) stroke. Rated power of 155-hp (116kW) at 2200 RPM. Maximum power of 160-hp (119kW) at 2000 rpm. Peak torque 440 ft-lbs. (596 N-m) at 1500 rpm. (SAE J1995 Conditions). Emission certification: US EPA Tier II, Carb Tier II, EU Stage II. Includes fuel/water separator and engine/transmission protection system. The fuel tank capacity is 21 gallons (79 L).

Air Cleaner

Donaldson dry air cleaner with safety element and restriction indicator.

Cooling System

Extra large crossflow radiator for maximum efficiency; low profile hood. Wide fin spacing reduces dirt build-up and provides optimum engine cooling.

Electrical, Instrumentation, and Accessories

The one-piece instrument panel flips down for easy servicing and is pre-wired to accommodate heavy-duty accessories. All wiring is color coded.

The unit has a 12-volt electrical system. Standard equipment includes a key-type ignition system, heavy-duty battery, 100-amp alternator, reset circuit breakers, lighted instruments, horn, key switch- actuated amber strobe light, reverse-actuated warning alarm and tilt steering.

Gauges include fuel level, hourmeter, air pressure, engine coolant temperature, and hydraulic oil temperature. Tier II engine electronic diagnostic light package.

Transmission

The three-speed, fully reversing, modulated, powershift transmission has inching, and electric roll shift control. Brakes behind inching. The filler pipe dipstick and large, heavy-duty, oil filter are easily accessible. Separate air-to-oil cooler.

Drive Axle

The bolted heavy-duty, planetary, drive axle utilizes a hypoid ring gear and pinion.

Steer Axle

The steer axle is a single hydraulic cylinder design with heavy-duty links from the cylinder ram directly to tapered roller bearing mounted spindles.

Brake System

The 17.25-in. (438 mm) diameter x 4-in. (178 mm) wide S-cam air service brakes utilize a pedal to combine transmission inching / disconnect with brake actuation and a separate pedal for brake actuation. The spring applied parking brake is mounted on the transmission output shaft; the parking brake control is mounted on the instrument panel.

Power Steering

The fully hydrostatic steer-on-demand steering system provides constant response at all engine speeds.

Chassis

The all-welded frame has an integral counterweight. Large hinged doors provide easy access to the battery and other service points. The adjustable, suspension seat has an operator seat belt.

Hydraulic System

The hydraulic system utilizes an accumulator (in the lift circuit), dual wire-mesh strainers and a full-flow, 10-micron return-line filter with a replaceable element in the tank. Service capacity is 26 gallons (98 L).

The gear-type pump is transmission driven. Control valves are separate, stacked, and spool-type. The tilt lock valve prevents mast drift and torsional stress.

The stud-mounted lift cylinder has a chrome-plated rod and self-adjusting packing. Tilt cylinders also have chrome plated rods and self-adjusting packing, and are low-mounted for increased operator visibility. The standard dual pilot operated levers are conveniently located.

Mast, Carriage, and Rollers

The 8-ft. (2.4 m) mast uprights and crossmembers are constructed of high-strength steel for minimum weight. The 2-stage, telescopic, direct lift mast has 40-in. (1,016 mm) of free lift provided by a 3-stage telescopic lift cylinder. Lifting eyes are standard. The mast can be safely and easily removed.

The pin-type “C” carriage has a high strength-to-weight ratio; forks are fully adjustable from 58-in. (1,473 mm) outside to 1-1/2-in. (38 mm) inside.

The mast and carriage main rollers are common and use shielded roller bearings. The side rollers are adjustable to compensate for wear. All rollers can be relubricated for maximum life.

Forks

The forks are hammer forged from heat treated alloy steel. 3-in. x 8-in. x 48-in. (76 mm x 203 mm x 1,219 mm).

This vehicle is certified to meet the applicable design and performance criteria required for Powered Industrial Trucks in OSHA Safety and Health Standards, Title 29 CFR, Part 1910.178, and the applicable design and performance requirements in ANSI B56.1 that were in effect at the time of manufacture. These standards also apply to the user and should be adhered to while operating this vehicle.

All specifications are subject to change without notice. Some operating data may be affected by the condition of the operating area. If these specifications are critical, contact the factory.