



“Big Red” THC-500L

Taylor Cushion Tire Industrial Truck Standard Specifications

THC-500L

Rated Capacity 50,000-lbs. (22,680 kg)

30-in. (762 mm) Load Center

110-in. (2,794 mm) Wheelbase



"Big Red" THC-500L

GENERAL	1	Manufacturer	Manufacturer's Name	TAYLOR		
	2	Model	Manufacturer's Designation	THC-500L		
				English	Metric	
	3	Capacity	Rated Capacity	lb (kg)	50,000 / 22,680	
	4	Load Center	Distance	in (mm)	30 / 762	
	5	Power Type	LPG, Or Diesel	Diesel		
	6	Tire Type	Cushion, Pneumatic Front / Rear	Cushion / Cushion		
	7	Wheels	Number (X = Driven) Front / Rear	2X / 2		
DIMENSIONS	8	Upright Lift	Lift - Min / Max (Top Of Ram)	in (mm)	22 / 92 / 559 / 2,337	
	8A		Free Lift	in (mm)	65 / 1,651	
	9	Ram	Outside Diameter	in (mm)	12 / 305	
	9A		Length	in (mm)	48 / 1,219	
	10	Tilt Angle	Standard Upright - Forward / Backward	deg.°	10 / 10	
	11	Overall Dimensions	Length To Face Of Ram	in (mm)	158 / 4,013	
	12		Width (Standard Tires)	in (mm)	70 / 1,778	
	13		Height, Standard Upright Lowered	in (mm)	147 / 3,734	
	14		Height, Standard Upright Extended (Top Of Carriage)	in (mm)	152 / 3,861	
	15		Height To Top Of Counterweight	in (mm)	62.25 / 1,581	
	16		Height To Top Of Overhead Guard	in (mm)	105.5 / 2,680	
	17	Turning Radius	Minimum Outside	in (mm)	151.75 / 3,855	
	17A		Minimum Inside	in (mm)	16.8 / 427	
	18	Load Distance	Center Of Wheel To Face Of Forks	in (mm)	24 / 610	
	19	Aisle Width	(Add Load Length For 90° Stacking)	in (mm)	182.6 / 4,638	
	PERFORMANCE	20	Stability	Comply With ANSI?	Yes	
		21	Speeds	Travel Speed - Maximum Forward	mph (km/h)	9.7 / 15.6
		22		Lift Speed - No Load	fpm (m/s)	25 / .13
		22A		Lift Speed - With Load	fpm (m/s)	- / -
23		Lowering Speed - No Load / With Load		fpm (m/s)	45 / .23	
24		Drawbar Pull		Powershift (Maximum At Stall)	lb (kN)	26,850 / 119
† 25		Gradeability	Powershift (Maximum At Stall) No Load	%	24.7	
25A	Powershift (Maximum At Stall) With Load		%	26.5		
WEIGHT	26	Ttl. Apprx. Wt.	Standard Truck	lb (kg)	55,000 / 24,948	
	27	Axle Loading	Static With Rated Load - Front	lb (kg)	97,000 / 43,999	
	27A		Static With Rated Load - Rear	lb (kg)	8,000 / 3,629	
	27B		Static With No Load - Front	lb (kg)	22,250 / 10,093	
	27C		Static With No Load - Rear	lb (kg)	32,750 / 14,855	
WHEELS / TIRES	28	Tires	Number - Front / Rear	2 / 2		
	29		Size - Front	36 x 20 x 30 Poly		
	30		Size - Rear	28 x 12 x 22 Poly		
	31	Wheelbase	Distance	in (mm)	110 / 2,794	
	32	Tread	Center Of Tires - Front	in (mm)	50 / 1,270	
	32A		Center Of Tires - Rear	in (mm)	58 / 1,473	
	33	Ground Clearance	No Load At Lowest Point	in (mm)	4.75 / 121	
	34		No Load At Center Of Wheelbase	in (mm)	7 / 178	
	35	Brakes	Service / Parking - Method Of Control	Foot / Hand		
	36		Service / Parking - Method Of Operation	Air / Air		
POWER UNITS / XMSN	37	Battery	Volts / Ampere Hours (1 Battery)	V/Ah	12 / 1000	
	38	Internal Combustion Engine	Make / Model	Cummins QSB5.9-30-C155		
	39		Output - Intermittent Per SAE Standards	hp (kW)	155 / 116	
	40		Governed Speed - With Load	rpm	2000	
	41		Cycle / Number Of Cylinders / Displacement	cu-in (L)	4 / 6 / 359	4 / 6 / 5.9
	42	Clutch	Type	Inching		
	43	Gear Change	Type	Hand		
	44	Transmission	Number Of Speeds - Forward / Reverse	3 / 3		
	45		Type	Powershift		
	46	Relief Press.	For Attachments	psi (bar)	1500 / 103	
47		Width Across Counterweight	in (mm)	70 / 1,778		
48		Load Moment	in-lbs (m-kg)	2,460,000 / 28,343		

† NOTE: Performance specifications are for trucks equipped as described on the back page of this specification sheet. Performance specifications are affected by the condition of the vehicle, its components, and the nature and condition of the operating area. If these specifications are critical, the proposed application should be discussed with your Taylor sales representative.

"Big Red" THC-500L

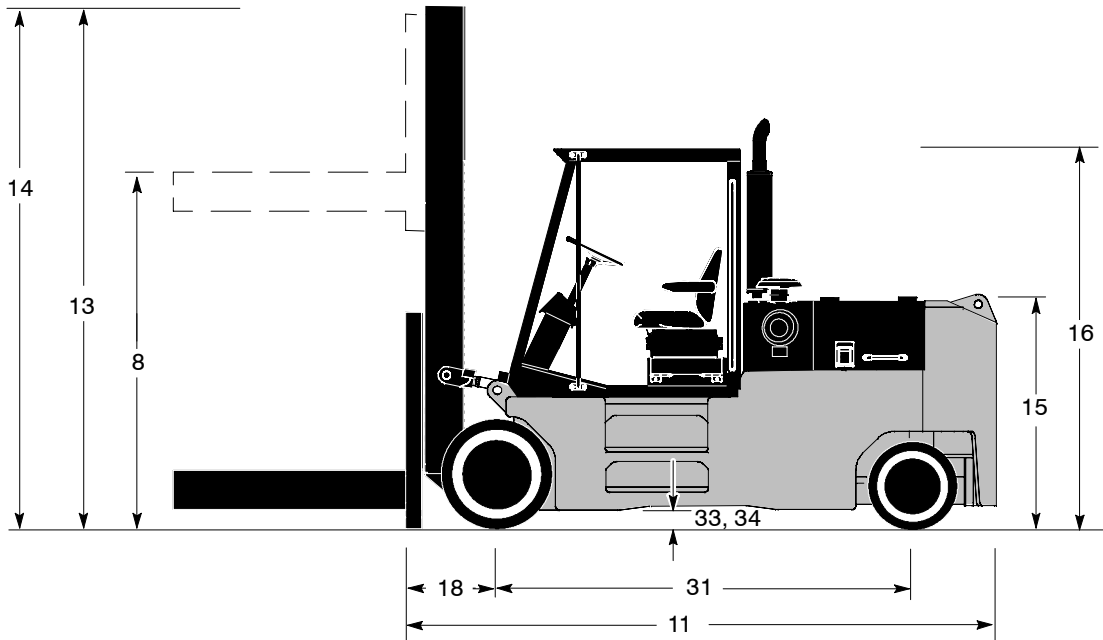
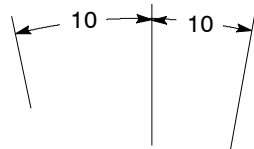
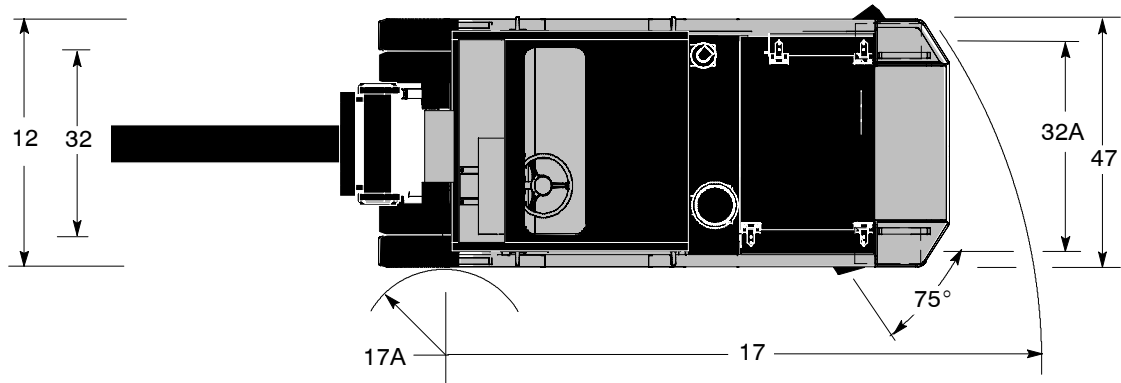

“Big Red” THC-500L

Engine

Cummins QSB5.9-30-C155 electronic turbocharged diesel, 6-cylinder diesel engine has 359 cu-in. (5.9 L) displacement. 4.02-in. (102 mm) bore x 4.72-in. (120 mm) stroke. Rated power of 155-hp (116kW) at 2200 RPM. Maximum power of 160-hp (119kW) at 2000 rpm. Peak torque 440 ft-lbs. (596 N-m) at 1500 rpm. (SAE J1995 Conditions). Emission certification: US EPA Tier II, Carb Tier II, EU Stage II. Includes fuel/water separator and engine/transmission protection system. The fuel tank capacity is 39 gallons (148 L).

Air Cleaner

Donaldson dry air cleaner with safety element and restriction indicator.

Cooling System

Extra large crossflow radiator for maximum efficiency; low profile hood. Wide fin spacing reduces dirt build-up and provides optimum engine cooling.

Electrical, Instrumentation, and Accessories

The one-piece instrument panel flips down for easy servicing and is pre-wired to accommodate heavy-duty accessories. All wiring is color coded.

The unit has a 12-volt electrical system. Standard equipment includes a key-type ignition system, heavy-duty battery, 100-amp alternator, reset circuit breakers, lighted instruments, horn, key switch- actuated amber strobe light, reverse-actuated warning alarm and tilt steering.

Gauges include fuel level, hourmeter, air pressure, engine coolant temperature, and hydraulic oil temperature. Tier II engine electronic diagnostic light package.

Transmission

The three-speed, fully reversing, modulated, powershift transmission has inching, and electric roll shift control. Brakes behind inching. The filler pipe dipstick and large, heavy-duty, oil filter are easily accessible. Separate air-to-oil cooler.

Drive Axle

The heavy-duty, planetary, drive axle utilizes a hypoid ring gear and pinion.

Steer Axle

The steer axle is a single hydraulic cylinder design with heavy-duty links from the cylinder ram directly to tapered roller bearing mounted spindles.

Brake System

The 20.25-in. (514 mm) diameter x 5-in. (102 mm) wide S-cam air service brakes utilize a pedal to combine transmission inching / disconnect with brake actuation and a separate pedal for brake actuation. The spring applied parking brake is mounted on the transmission output shaft; the parking brake control is mounted on the instrument panel.

Power Steering

The fully hydrostatic steer-on-demand steering system provides constant response at all engine speeds.

Chassis

The all-welded frame has an integral counterweight. Large hinged doors provide easy access to the battery and other service points. The adjustable, suspension seat has an operator seat belt.

Hydraulic System

The hydraulic system utilizes an accumulator (in the lift circuit), dual wire-mesh strainers and a full-flow, 10-micron return-line filter with a replaceable element in the tank. Service capacity is 47 gallons (178 L).

The gear-type pump is transmission driven. Control valves are separate, stacked, and spool-type. The tilt lock valve prevents mast drift and torsional stress.

The stud-mounted lift cylinder has a chrome-plated rod and self-adjusting packing. Tilt cylinders also have chrome plated rods and self-adjusting packing, and are low-mounted for increased operator visibility. The standard dual pilot operated levers are conveniently located.

Mast, Carriage, and Rollers

The 70-in. (1,778mm) mast uprights and crossmembers are constructed of high-strength steel for minimum weight. The rigid direct lift mast has 65-in. (1,651 mm) of free lift provided by a telescopic lift cylinder. Lifting eyes are standard. The mast can be safely and easily removed.

Integral coil ram carriage.

The mast and carriage main rollers are common and use shielded roller bearings. The side rollers are adjustable to compensate for wear. All rollers can be relubricated for maximum life.

Coil Ram

12-in. (305 mm) outside diameter, 48-in. (1,219 mm) long and top of ram is 22-in. (559 mm) from ground.

This vehicle is certified to meet the applicable design and performance criteria required for Powered Industrial Trucks in OSHA Safety and Health Standards, Title 29 CFR. Part 1910.178, and the applicable design and performance requirements in ANSI B56.1 that were in effect at the time of manufacture. These standards also apply to the user and should be adhered to while operating this vehicle.

All specifications are subject to change without notice. Some operating data may be affected by the condition of the operating area. If these specifications are critical, contact the factory.