



“Big Red” TMH-125

Taylor Marina Truck Preliminary Specifications Center Mounted Operator And Two Stage Wide Mast

TMH-125 Rated Capacities*

12,500-lbs. (5,670 kg) Capacity to 30-ft. (9.14 m)
17,500-lbs. (7,938 kg) Capacity to 20-ft. (6.09 m)
25,000-lbs. (11,340 kg) Capacity to 10-ft. (3.04 m)

96-in. (2,438 mm) Load Center
140-in. (3,556 mm) Wheelbase

*See next page for explanation of capacity ratings with attachment options.

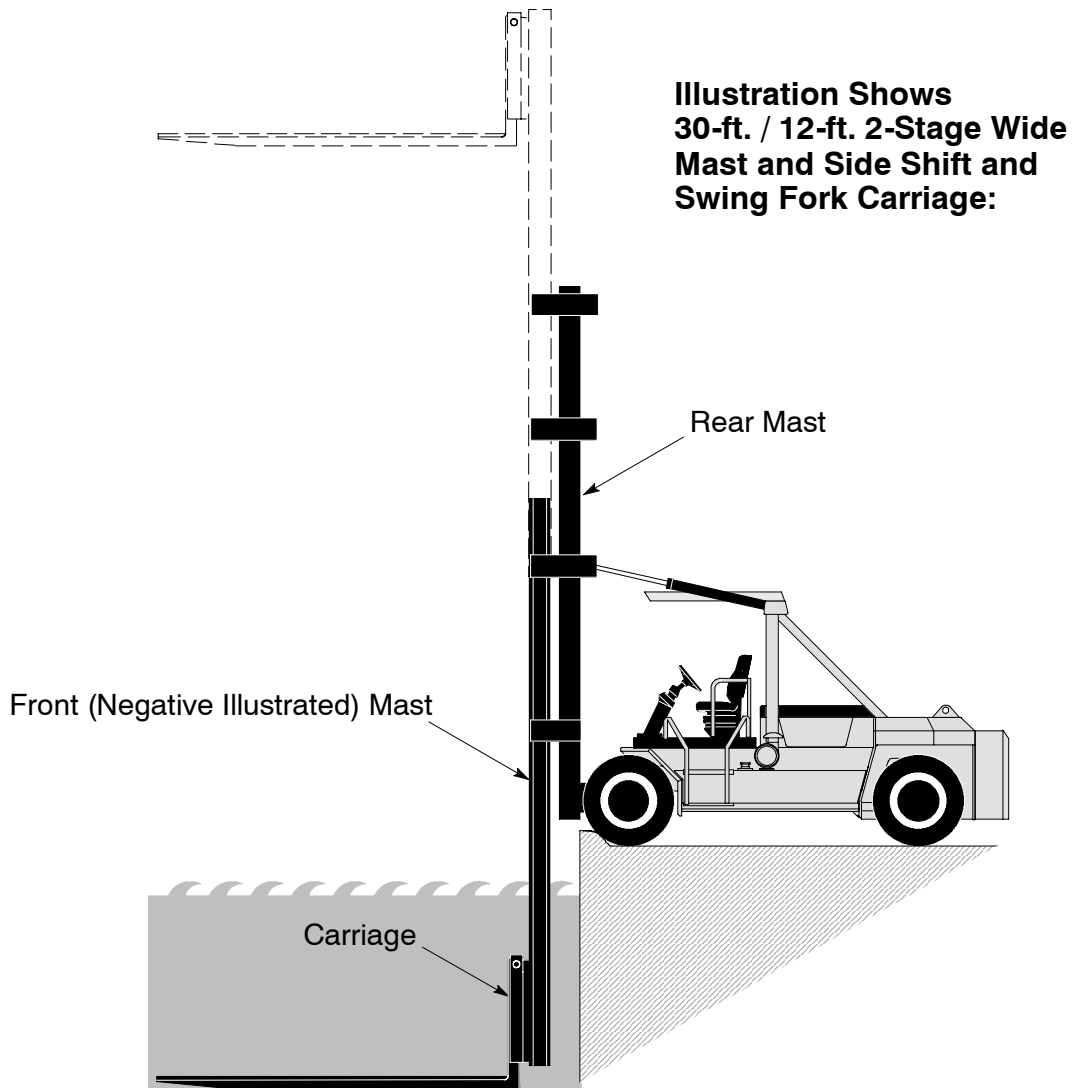

"Big Red" TMH-125 Marina Truck with Special Rating, Center Mounted Operator and 2-Stage Mast

GENERAL	1.	Manufacturer	Manufacturer's Name	TAYLOR			
	2.	Model	Manufacturer's Designation	TMH-125 w/2-stage Mast**			
GENERAL				English	Metric		
	GENERAL	3.	Capacity	Rated Capacity to 30-ft. (9.14 m)	lb (kg)	12,500 / 5,670	
Rated Capacity to 20-ft. (6.09 m)				lb (kg)	17,500 / 7,938		
Rated Capacity to 10-ft. (3.04 m)				lb (kg)	25,000 / 11,340		
GENERAL	4.	Load Center	Distance	in (mm)	96 / 2,438		
GENERAL	5.	Power Type	Gas, LPG, Or Diesel		Diesel		
GENERAL	6.	Tire Type	Front / Rear		Solid / Solid		
GENERAL	7.	Wheels	Number (X = Driven) Front / Rear		4X / 2		
DIMENSIONS	8.	Upright Lift	Positive Lift (Top Of Fork) (Includes Fork Thickness)	in (mm)	368 / 9,347		
	8A.		Reach Below Ground Level (Negative Lower) (Bottom of Fork)	in (mm)	-144 / -3,658		
	8B.		Free-Lift (Ground To Top of Fork)	in (mm)	216 / 5,486		
	DIMENSIONS	9.	Forks	Thickness	in (mm)	10 / 254	
				Width	in (mm)	8 / 203	
				Length	in (mm)	240 / 6,096	
	DIMENSIONS	10.	Tilt Angle	Standard Upright - Forward / Backward	deg.°	2 / 5	
	DIMENSIONS	11.	Overall Dimensions	Length To Face Of Forks	in (mm)	238 / 6,045	
				Width (Standard Tires)	in (mm)	103 / 2,616	
				Height, Upright Lowered	in (mm)	285 / 7,239	
				Height, Upright Extended	in (mm)	430 / 10,922	
				Height To Top Of Counterweight	in (mm)	63 / 1,600	
				Height To Top Of Overhead Guard	in (mm)	129 / 3,277	
				Turning Radius	Minimum Outside	in (mm)	209 / 5,309
	DIMENSIONS	17A.	Turning Radius	Minimum Inside	in (mm)	26 / 660	
				Load Distance	Center Of Wheel To Face Of Forks	in (mm)	53 / 1,346
				Aisle Width	(Add Load Length For 90° Stacking)	in (mm)	262 / 6,655
	PERFORMANCE	20.	Stability	Comply With ANSI?		Yes	
		PERFORMANCE	21.	Speeds	Travel Speed - Maximum Forward	mph (km/h)	12 / 19.3
Lift Speed - No Load					fpm (m/s)	58 / 0.29	
Lift Speed - With Load					fpm (m/s)	52 / 0.26	
Lowering Speed - No Load / With Load					fpm (m/s)	46 / 51 / 0.23 / 0.26	
PERFORMANCE		24.	Drawbar Pull	Powershift (Maximum At Stall)	lb (kN)	23,800 / 106	
PERFORMANCE	25.	Gradeability	Powershift (Maximum At Stall) No Load	%	34		
			Powershift (Maximum At Stall) With Load	%	31		
WEIGHTS	26.	Ttl. Apprx. Wt.	Standard Truck	lb (kg)	75,000 / 34,020		
	WEIGHTS	27.	Axle Loading	Static With Rated Load - Front	lb (kg)	93,300 / 42,321	
				Static With Rated Load - Rear	lb (kg)	6,700 / 3,039	
				Static With No Load - Front	lb (kg)	41,700 / 18,915	
				Static With No Load - Rear	lb (kg)	33,300 / 15,105	
WHEELS / TIRES	28.	Tires	Number - Front / Rear		4 / 2		
	29.		Size - Front		12.00 x 20 - Solid White		
	30.	Size - Rear		12.00 x 20 - Solid White			
	31.	Wheelbase	Distance	in (mm)	140 / 3,556		
	WHEELS / TIRES	32.	Tread	Center Of Outside (Dual) Tires - Front	in (mm)	90 / 2,286	
				Center Of Tires - Rear	in (mm)	80 / 2,032	
	WHEELS / TIRES	33.	Ground Clearance	No Load At Lowest Point	in (mm)	8 / 203	
				No Load At Center Of Wheelbase	in (mm)	16 / 406	
	WHEELS / TIRES	35.	Brakes	Service / Parking - Method Of Control		Foot / Hand	
				Service / Parking - Method Of Operation		Air / Spring	
POWER UNITS / XMSN	37.	Battery	Volts / Ampere Hours (1 Battery)	V/Ah	12 / 1150		
	POWER UNITS / XMSN	38.	Internal Combustion Engine	Make / Model		Cummins QSB5.9-30	
				Output - Intermittent Per SAE Standards	hp (kW)	160 / 119	
				Governed Speed - With Load	rpm	2,200	
				Cycle / Number Of Cylinders / Displacement	cu-in (L)	4 / 6 / 359 / 4 / 6 / 5.9	
				Clutch	Type	Inching	
	39.	Gear Change	Type	Hand			
POWER UNITS / XMSN	44.	Transmission	Number Of Speeds - Forward / Reverse		3 / 3		
			Type		Powershift		
POWER UNITS / XMSN	46.	Relief Pressure	For Attachments	psi (bar)	1,500 / 103		
			Width Across Counterweight	in (mm)	95.5 / 2,426		
			Fork Spread (Inside) - Max. / Min. (Integral Style)	in (mm)	77.5 / 5.5 / 1,969 / 140		
POWER UNITS / XMSN	49.	Ground To Top Of Carriage	in (mm)	68.5 / 1,740			
POWER UNITS / XMSN	50.	Load Moment At Floor Level	in-lbs (m-kg)	3,725,000 / 42,949			

† NOTE: Performance specifications are for trucks equipped as described on the back page of this specification sheet. Performance specifications are affected by the condition of the vehicle, its components, and the nature and condition of the operating area. If these specifications are critical, the proposed application should be discussed with your Taylor sales representative.

“Big Red” TMH-125 Marina Truck with Special Rating, Center Mounted Operator and 2-Stage Mast

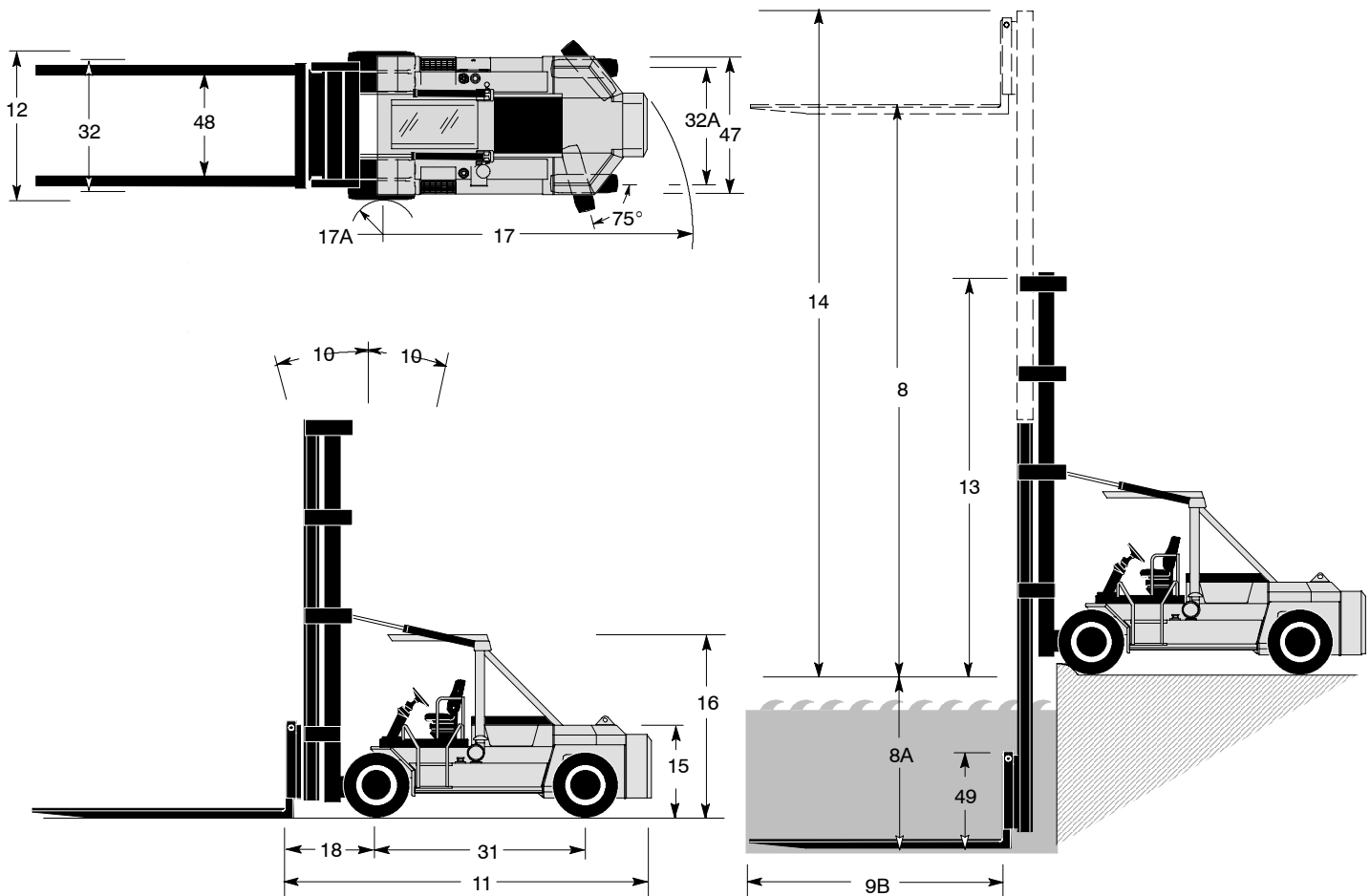

Taylor Marina Lift Trucks are designed specifically for marina applications: for placing boats in dry storage facilities and retrieving them from dry storage facilities and placing them in the water.

The Taylor Marina Truck is shown with a two-stage wide mast that permits 30-ft. (9.14 m) of positive lift without sacrificing storage space near the ceiling and permitting passage through existing doors. The front mast provides negative lower up to 12-ft. (3.66 m) and 216-in. (5,486 mm) “free-lift” to permit traveling with the boat at the carry position with no increase in collapsed height. The carriage is equipped with hydraulic side shifting capabilities and fork positioning or swing forks. Fork positioners or swing forks allow the operator to adjust the forks to precisely the proper spread needed for maximum support of any type hull; the side-shift feature enables the operator to position a boat in the rack without moving the truck.

Rear mast, front mast, fork carriage, and forks are controlled by independent levers assuring positive control at any position for maneuvering or placement of the load.

Features:

- Turbocharged diesel engine
- Lockable fuel tank
- Dry air cleaner with safety element and restriction indicator
- 3-speed powershift transmission with inching control
- Heavy-duty battery (12 Volt)
- Straight air service brakes
- Spring-applied parking brake
- Center mount operator station with pilot operated controls
- Overhead guard with high-mounted tilt cylinders
- Chrome-plated hydraulic cylinders
- Corrosion resistant coating on all painted surfaces
- Remote ground control pendant with coiled cord for in-water, unloaded fork height (lift / lower only) positioning
- Front splash guard
- Spray-on corrosion resistant coating to protect, mast, carriage, and forks.

Options:

- Worklights
- Cold weather starting aid
- Engine protection system
- Fire extinguisher
- 2-stage mast with 30-ft. (9.14 m) positive and 12-ft. (3.66 m) negative lower, with a Side Shift and Swing Fork Type Carriage.
- Forks with sectional white soft pads

Grades in excess of 5° (9%) may require factory adjustment of backward tilt. Contact Taylor Engineering if this (or and) specification is critical.

** Capacities are with 2 stage 30-ft. (9.14 m) positive lift and 12-ft.. (3.66 m) negative lower, with carriage and 20-ft.. (6,096 mm) forks. For capacities with other attachments contact factory.

“Big Red” TMH-125 Marina Truck with Special Rating, Center Mounted Operator and 2-Stage Mast

Engine

Cummins QSB5.9-30 electronic turbocharged diesel, 6-cylinder engine. 359 cu-in. (5.9 L) displacement. 4.02-in. (102 mm) bore x 4.72-in. (120 mm) stroke. Peak power 160 horsepower (119 kW) at 2000 rpm. Peak torque 440 ft.-lbs. (596 N-m) at 1500 rpm. (SAE J1995 Conditions)

Emission certification: US EPA Tier II, Carb Tier II, EU Stage II.

The fuel tank capacity is 50 gallons (189 L).

Includes engine and transmission protection system.

Air Cleaner

The dry type air cleaner is equipped with a safety element and restriction indicator.

Cooling System

The cooling system uses a conventional top / bottom tank radiator. Wide fin spacing reduces dirt build-up and provides optimum engine cooling.

Electrical, Instrumentation, and Accessories

The unit has a 12 volt electrical system, heavy duty battery, 100 amp alternator, and all wiring is color coded.

Standard gauges are mechanical, eliminating potential corrosive effects of sea water on electrical instrumentation. The lighted gauges are: transmission oil pressure, transmission oil temperature, engine oil pressure, engine temperature, and air pressure.

An electrical fuel gauge and a single cluster of warning lights, which include low air, seat belt, parking brake, and battery indicator, along with a key-type anti-restart ignition switch, sealed light switch, forward alarm switch, air horn, keyswitch-actuated amber strobe light, reverse-actuated warning horn, circuit breakers, and relays have been removed from the steering console to a sealed, corrosive-proof fiberglass panel, mounted to the operator's right.

Unloaded fork carriage lift and lower functions may be controlled from the ground with a two-button electrical pendant on a 20-ft. coiled cord that conveniently stores on the left front fender.

The unit has tilt steering and rearview mirrors.

Transmission

The three-speed, fully reversing, modulated, powershift transmission has a foot controlled inching pedal with brakes behind inching. The transmission has sealed electric shift controls and a separate air-to-oil cooler. The filler pipe dipstick and large, heavy-duty, spin-on oil filter are easily accessible.

Drive Axle

The bolted heavy-duty planetary drive axle utilizes a hypoid ring gear and pinion.

Steer Axle

The steer axle is a single hydraulic cylinder design with heavy-duty links directly from the cylinder ram to tapered roller bearing mounted spindles.

Brake System

The 16.5-in. (419 mm) diameter x 7-in. (178 mm) wide S-cam service brakes utilize a pedal to combine transmission inching / disconnect with brake actuation and a separate pedal for brake actuation. The parking brake is spring-applied with instrument panel mounted control.

Power Steering

The fully hydrostatic, steer-on-demand steering system provides constant response at all engine speeds.

Chassis

The all-welded frame has an integral counterweight and a bolt-on weight on the rear. The engine compartment has a spring-assisted hood for service access. The center mounted operator station is positioned for optimum visibility forward and rearward, with easy access from both sides of the machine. An overhead guard has a tough, tinted plastic skyview window. The vinyl-covered suspension seat (with an operator seat belt) is fully adjustable.

Hydraulic System

The large capacity hydraulic tank has a spin-on tank breather, wire-mesh strainers, and a full-flow 10-micron return-line filter with a replaceable element in the tank. The filter condition indicator is mounted on the instrument panel. The tank refill capacity is 70 gallons (265 L).

The hydraulic system utilizes a gear-type pump. Control valves are separate, stacked, and spool-type. The tilt-lock valve prevents mast drift and reduces torsional stress.

Self-aligning, bearing-mounted, lift cylinders have chrome-plated rods and self-adjusting packing. Pilot operated control levers are conveniently located.

Optional Mast

The wide two-stage mast design places the rails of the front mast before the rear rails to increase the open viewing area, providing highly improved forward visibility. The carriage lift/lower cylinders operate in tension, allowing smaller diameter rods and cylinder barrels that also improve forward visibility.

The optional mast has 30-ft. (9.14 m) positive lift and 12-ft (3.6 m) negative lower with one of the following carriages:

Optional Carriage

Side Shift and Swing fork type carriage.

Optional Forks

The pin-mounted, square tip, bottom tapered forks are fabricated. The standard fork size is 8-in. x 10-in. x 240-in. (203 mm x 254 mm x 6,096 mm).

Note: Illustrations of equipment may sometimes show optional equipment not included on a standard model.

This vehicle is certified to meet the applicable design and performance criteria required for Powered Industrial Trucks in OSHA Safety and Health Standards, Title 29 CFR, Part 1910.178, and the applicable design and performance requirements in ANSI B56.1 that were in effect at the time of manufacture. These standards also apply to the user and should be adhered to while operating this vehicle.

All specifications are subject to change without notice. Some operating data may be affected by the condition of the operating area. If these specifications are critical, contact the factory.

Taylor Machine Works, Inc.

650 North Church Avenue
Louisville, Mississippi 39339-2017
Phone (662) 773-3421 Fax (662) 773-9146

AD1 (7/07)
Printed in U.S.A.