



“Big Red” TMHO-120

Taylor Marina Truck Preliminary Specifications Offset Operator And Three Stage Mast

TMHO-120 Rated Capacities*

12,000-lbs. (5,443 kg) Capacity to 30-ft. (9.14 m)
14,000-lbs. (6,350 kg) Capacity to 20-ft. (6.10 m)
16,000-lbs. (7,258 kg) Capacity to 11-ft. (3.35 m)
20,000-lbs. (9,072 kg) Capacity to 10-ft. (3.04 m)

96-in. (2,438 mm) Load Center
125-in. (3,175 mm) Wheelbase

*See next page for explanation of capacity ratings with attachment options.

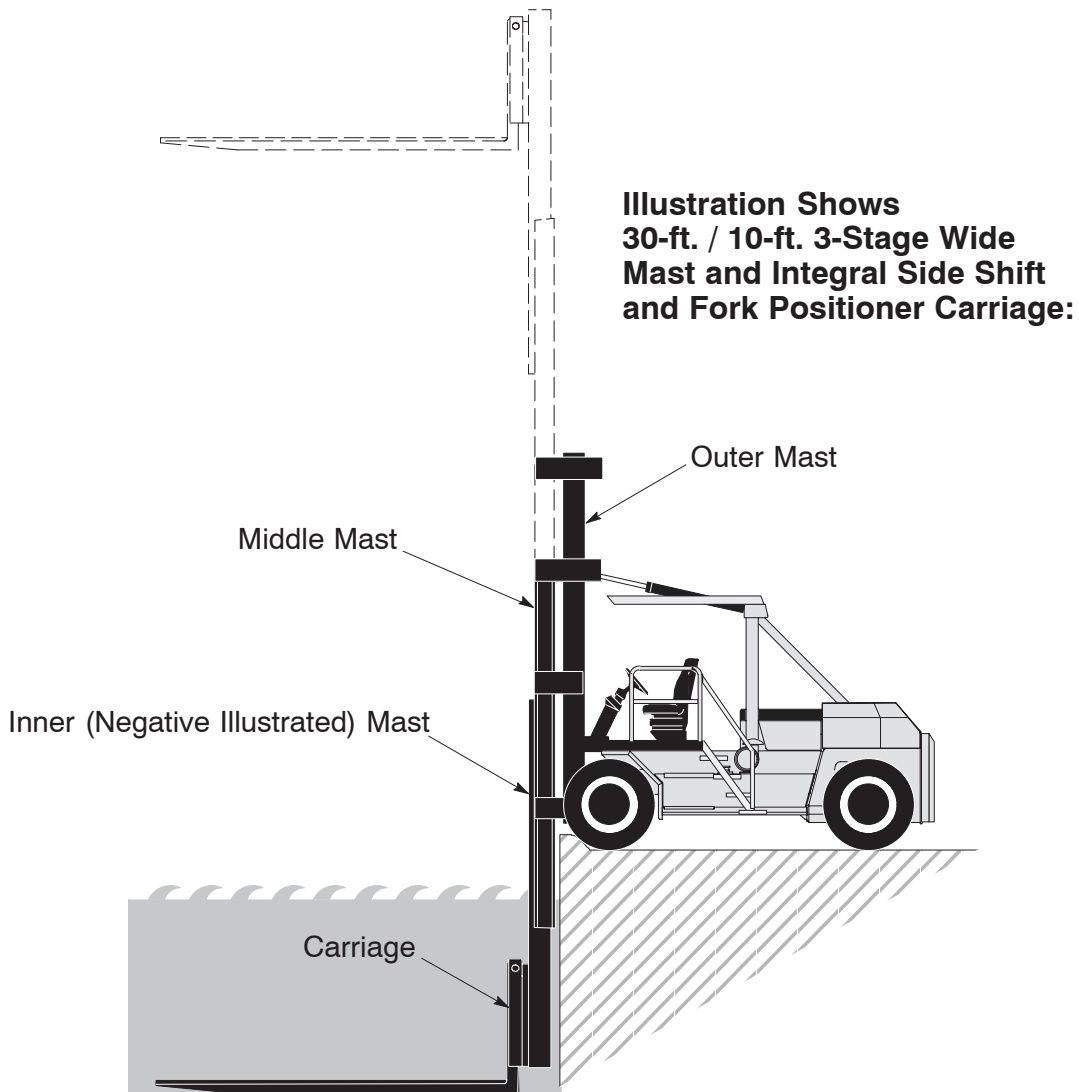

"Big Red" TMHO-120 Marina Truck with Offset Operator and 3-Stage Mast

GENERAL	1.	Manufacturer	Manufacturer's Name	TAYLOR		
	2.	Model	Manufacturer's Designation	TMHO-120 w/3-stage Mast**		
GENERAL				English	Metric	
	GENERAL	3.	Capacity	Rated Capacity to 30-ft. (9.14 m)	lb (kg)	12,000 (5,443)
Rated Capacity to 20-ft. (6.10 m)				lb (kg)	14,000 (6,350)	
Rated Capacity to 11-ft. (3.35 m)				lb (kg)	16,000 (7,258)	
Rated Capacity to 10-ft. (3.04 m)				lb (kg)	20,000 (9,072)	
GENERAL	4.	Load Center	Distance	in (mm)	96 (2,438)	
GENERAL	5.	Power Type	Gas, LPG, Or Diesel	Diesel		
GENERAL	6.	Tire Type	Cushion, Pneumatic Front / Rear	Pneumatic / Pneumatic		
GENERAL	7.	Wheels	Number (X = Driven) Front / Rear	4X / 2		
DIMENSIONS	8.	Upright Lift	Positive Lift (Top Of Fork) (Includes Fork Thickness)	in (mm)	368 (9,347)	
	8.A		Reach Below Ground Level (Negative Lower) (Bottom of Fork)	in (mm)	-120 (-3,048)	
	8.B		Free-Lift (Ground To Top of Fork)	in (mm)	120 (3,048)	
	GENERAL	9.	Forks	Thickness	in (mm)	8 (203)
	9.A	Width		in (mm)	8 (203)	
	9.B	Length		in (mm)	240 (6,096)	
	GENERAL	10.	Tilt Angle	Standard Upright - Forward / Backward	deg.°	2 / 5
	GENERAL	11.	Overall Dimensions	Length To Face Of Forks	in (mm)	217 (5,512)
	GENERAL	12.		Width (Standard Tires)	in (mm)	103 (2,616)
	GENERAL	12.A		Overall Width At Operator's Station	in (mm)	117 (2,972)
	GENERAL	13.		Height, Upright Lowered	in (mm)	188 (4,775)
	GENERAL	14.		Height, Upright Extended	in (mm)	428 (10,871)
	GENERAL	15.		Height To Top Of Counterweight	in (mm)	67 (1,702)
	GENERAL	16.		Height To Top Of Overhead Guard	in (mm)	129 (3,277)
	GENERAL	17.	Turning Radius	Minimum Outside	in (mm)	184 (4,674)
	GENERAL	17.A		Minimum Inside	in (mm)	18 (457)
	GENERAL	18.	Load Distance	Center Of Wheel To Face Of Forks	in (mm)	54.6 (1,387)
	GENERAL	19.	Aisle Width	(Add Load Length For 90° Stacking)	in (mm)	239 (6,071)
	PERFORMANCE	20.	Stability	Comply With ANSI?	Yes	
GENERAL		Speeds	Travel Speed - Maximum Forward	mph (km/h)	12 (19.3)	
GENERAL			Lift Speed - No Load	fpm (m/s)	75 (0.38)	
GENERAL			Lift Speed - With Load	fpm (m/s)	70 (0.36)	
GENERAL			Lowering Speed - No Load / With Load	fpm (m/s)	65 (0.33)	
GENERAL		24.	Drawbar Pull	Powershift (Maximum At Stall)	lb (kN)	23,800 (106)
GENERAL		25.	Gradeability	Powershift (Maximum At Stall) No Load	%	34
GENERAL	25.A	Powershift (Maximum At Stall) With Load		%	31	
WEIGHT	26.	Ttl. Apprx. Wt.	Standard Truck	lb (kg)	66,400 (30,119)	
	GENERAL	Axle Loading	Static With Rated Load - Front	lb (kg)	80,000 (36,288)	
	GENERAL		Static With Rated Load - Rear	lb (kg)	6,400 (2,903)	
	GENERAL		Static With No Load - Front	lb (kg)	35,900 (16,284)	
	GENERAL		Static With No Load - Rear	lb (kg)	30,500 (13,835)	
WHEELS / TIRES	28.	Tires	Number - Front / Rear	4 / 2		
	GENERAL		Size - Front	12.00 x 20 - 20 PR		
	GENERAL		Size - Rear	12.00 x 20 - 20 PR		
	GENERAL	31.	Wheelbase	Distance	in (mm)	125 (3,175)
	GENERAL	32.	Tread	Center Of Outside (Dual) Tires - Front	in (mm)	90 (2,286)
	GENERAL	32.A		Center Of Tires - Rear	in (mm)	80 (2,032)
	GENERAL	33.	Ground Clearance	No Load At Lowest Point	in (mm)	9 (229)
	GENERAL	34.	Ground Clearance	No Load At Center Of Wheelbase	in (mm)	16 (406)
	GENERAL	35.	Brakes	Service / Parking - Method Of Control	Foot / Hand	
	GENERAL	36.		Service / Parking - Method Of Operation	Air / Spring	
POWER UNITS / XMS	37.	Battery	Volts / Ampere Hours (1 Battery)	V/Ah	12 / 1150	
	GENERAL	38.	Make / Model	Cummins QSB5.9-30		
	GENERAL	39.	Internal Combustion Engine	Output - Intermittent Per SAE Standards	hp (kW)	160 (119)
	GENERAL	40.		Governed Speed - With Load	rpm	2,200
	GENERAL	41.		Cycle / Number Of Cylinders / Displacement	cu-in (L)	4 / 6 / 359 (4 / 6 / 5.9)
	GENERAL	42.	Clutch	Type	Inching	
	GENERAL	43.	Gear Change	Type	Hand	
GENERAL	44.	Transmission	Number Of Speeds - Forward / Reverse	3 / 3		
GENERAL	45.		Type	Powershift		
GENERAL	46.	Relief Pressure	For Attachments	psi (bar)	1,500 (103)	
GENERAL	47.	Width Across Counterweight	in (mm)	95.5 (2,426)		
GENERAL	48.	Fork Spread(Inside) - Max. / Min. (Integral Style)	in (mm)	77.5 / 5.5 (1,969 / 140)		
GENERAL	49.	Ground To Top Of Carriage	in (mm)	68.5 (1,740)		
GENERAL	50.	Load Moment At Floor Level	in-lbs (m-kg)	3,012,000 (34,702)		

† NOTE: Performance specifications are for trucks equipped as described on the back page of this specification sheet. Performance specifications are affected by the condition of the vehicle, its components, and the nature and condition of the operating area. If these specifications are critical, the proposed application should be discussed with your Taylor sales representative.

“Big Red” TMHO-120 Marina Truck with Offset Operator and 3-Stage Mast

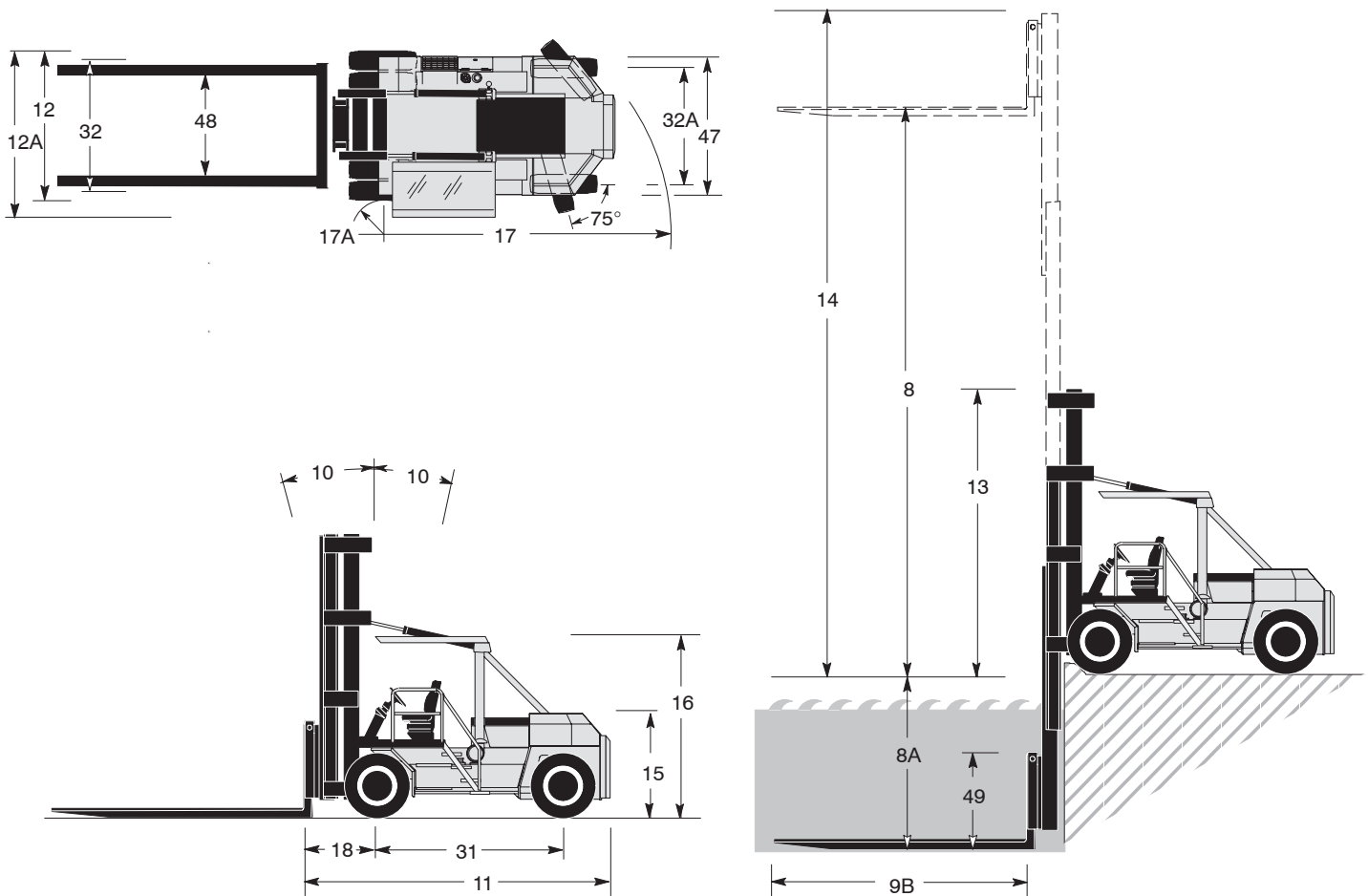

Taylor Marina Lift Trucks are designed specifically for marina applications: for placing boats in dry storage facilities and retrieving them from dry storage facilities and placing them in the water.

The Taylor Marina Truck is shown with a three-stage mast that permits 30-ft. (9.14 m) of positive lift without sacrificing storage space near the ceiling and permitting passage through existing doors. The mast provides negative lower up to 10-ft. (3.05 m) and 120-in. (3,048 mm) “free-lift” to permit traveling with the boat at the carry position with no increase in collapsed height. The carriage is equipped with hydraulic side shifting capabilities and fork positioning or swing forks. Fork positioners or swing forks allow the operator to adjust the forks to precisely the proper spread needed for maximum support of any type hull; the side-shift feature enables the operator to position a boat in the rack without moving the truck.

Mast, front mast, fork carriage, and forks are controlled by independent levers assuring positive control at any position for maneuvering or placement of the load.

Features:

- Turbocharged diesel engine
- Lockable fuel tank
- Dry air cleaner with safety element and restriction indicator
- 3-speed powershift transmission with inching control
- Heavy-duty battery (12 Volt)
- Straight air service brakes
- Spring-applied parking brake
- Offset operator station with pilot operated controls
- Overhead guard with high-mounted tilt cylinders
- Chrome-plated hydraulic cylinders
- Corrosion resistant coating on all painted surfaces
- Remote ground control pendant with coiled cord for in-water, unloaded fork height (lift / lower only) positioning
- Front splash guard
- Spray-on corrosion resistant coating to protect, mast, carriage, and forks.

Options:

- Worklights
- Cold weather starting aid
- Engine protection system
- Fire extinguisher
- 3-stage mast with 30-ft. (9.14 m) positive and 10-ft. (3.05 m) negative lower, with either a Type “C” Carriage with integral side shift and fork positioners; or a Side Shift and Swing Fork Type Carriage.
- Forks with sectional white soft pads

Grades in excess of 5° (9%) may require factory adjustment of backward tilt. Contact Taylor Engineering if this (or and) specification is critical.

** Capacities are with 3 stage 30-ft. (9.14 m) positive lift and 10-ft.. (3.05 m) negative lower, with either type carriage and 20-ft.. (6,096 mm) forks.

For capacities with other attachments contact factory.

“Big Red” TMHO-120 Marina Truck with Offset Operator and 3-Stage Mast

Engine

Cummins QSB5.9-30 electronic turbocharged diesel, 6-cylinder engine. 359 cu-in. (5.9 L) displacement. 4.02-in. (102 mm) bore x 4.72-in. (120 mm) stroke. Peak power 160 horsepower (119 kW) at 2000 rpm. Peak torque 440 ft.-lbs. (596 N-m) at 1500 rpm. (SAE J1995 Conditions)

Emission certification: US EPA Tier II, Carb Tier II, EU Stage II.

The fuel tank capacity is 50 gallons (189 L).

Includes engine and transmission protection system.

Air Cleaner

The dry type air cleaner is equipped with a safety element and restriction indicator.

Cooling System

The cooling system uses a conventional top / bottom tank radiator. Wide fin spacing reduces dirt build-up and provides optimum engine cooling.

Electrical, Instrumentation, and Accessories

The unit has a 12 volt electrical system, heavy duty battery, 100 amp alternator, and all wiring is color coded.

Standard gauges are mechanical, eliminating potential corrosive effects of sea water on electrical instrumentation. The lighted gauges are: transmission oil pressure, transmission oil temperature, engine oil pressure, engine temperature, and air pressure.

An electrical fuel gauge and a single cluster of warning lights, which include low air, seat belt, parking brake, and battery indicator, along with a key-type anti-restart ignition switch, sealed light switch, forward alarm switch, air horn, keyswitch-actuated amber strobe light, reverse-actuated warning horn, circuit breakers, and relays have been removed from the steering console to a sealed, corrosive-proof fiberglass panel, mounted to the operator's right.

Unloaded fork carriage lift and lower functions may be controlled from the ground with a two-button electrical pendant on a 20-ft. coiled cord that conveniently stores on the left front fender.

The unit has tilt steering and rearview mirrors.

Transmission

The three-speed, fully reversing, modulated, powershift transmission has a foot controlled inching pedal with brakes behind inching. The transmission has sealed electric shift controls and a separate air-to-oil cooler. The filler pipe dipstick and large, heavy-duty, spin-on oil filter are easily accessible.

Drive Axle

The bolted heavy-duty planetary drive axle utilizes a hypoid ring gear and pinion.

Steer Axle

The steer axle is a single hydraulic cylinder design with heavy-duty links directly from the cylinder ram to tapered roller bearing mounted spindles.

Brake System

The 16.5-in. (419 mm) diameter x 7-in. (178 mm) wide S-cam service brakes utilize a pedal to combine transmission inching / disconnect with brake actuation and a separate pedal for brake actuation. The parking brake is spring-applied with instrument panel mounted control.

Power Steering

The fully hydrostatic, steer-on-demand steering system provides constant response at all engine speeds.

Chassis

The all-welded frame has an integral counterweight and a bolt-on weight on the rear. The engine compartment has a spring-assisted hood for service access. The offset mounted operator station is positioned forward over the left front drive wheels for optimum visibility forward and rearward, with easy access from both sides of the machine. An overhead guard has a tough, tinted plastic skyview window. The vinyl-covered suspension seat (with an operator seat belt) is fully adjustable.

Hydraulic System

The large capacity hydraulic tank has a spin-on tank breather, wire-mesh strainers, and a full-flow 10-micron return-line filter with a replaceable element in the tank. The filter condition indicator is mounted on the instrument panel. The tank refill capacity is 60 gallons (227 L).

The hydraulic system utilizes a gear-type pump. Control valves are separate, stacked, and spool-type. The tilt-lock valve prevents mast drift and reduces torsional stress.

Self-aligning, bearing-mounted, lift cylinders have chrome-plated rods and self-adjusting packing. Pilot operated control levers are conveniently located.

Optional Mast

The three-stage mast design provides low overall height of mast when lowered.

The optional mast has 30-ft. (9.14 m) positive lift and 10-ft (3.05 m) negative lower with one of the following carriages:

Optional Carriages

- A. Type C Carriage with integral side shift and fork positioners; or
- B. Side Shift and Swing fork type carriage.

Optional Forks

The pin-mounted, square tip, bottom tapered forks are fabricated. The standard fork size is 8-in. x 8-in. x 240-in. (203 mm x 203 mm x 6,096 mm).

Note: Illustrations of equipment may sometimes show optional equipment not included on a standard model.

This vehicle is certified to meet the applicable design and performance criteria required for Powered Industrial Trucks in OSHA Safety and Health Standards, Title 29 CFR, Part 1910.178, and the applicable design and performance requirements in ANSI B56.1 that were in effect at the time of manufacture. These standards also apply to the user and should be adhered to while operating this vehicle.

All specifications are subject to change without notice. Some operating data may be affected by the condition of the operating area. If these specifications are critical, contact the factory.

Taylor Machine Works, Inc.

650 North Church Avenue
Louisville, Mississippi 39339-2017
Phone (662) 773-3421 Fax (662) 773-9146

AD (9/05)
Printed in U.S.A.