



“Big Red”

TX-160 / TX-175

**Taylor Industrial Trucks
Preliminary Specifications**

TX-160 Rated Capacity 16,000-lbs. **(7,258 kg)**

TX-175 Rated Capacity 17,500-lbs. **(7,938 kg)**

24-in. **(610 mm)** Load Center

97-in. **(2,464 mm)** Wheelbase

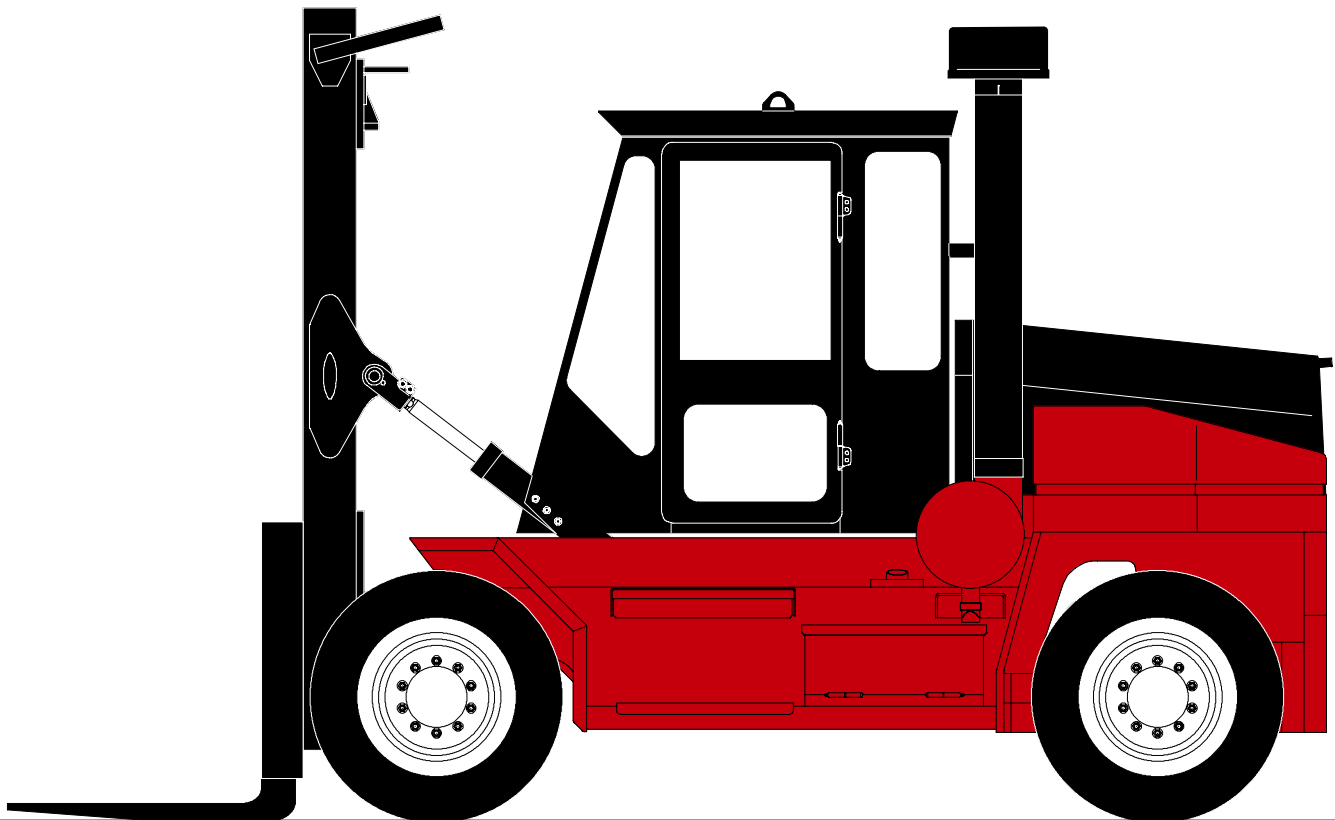

"Big Red" TX-160 / TX-175

GENERAL	1.	Manufacturer	Manufacturer's Name	TAYLOR		TAYLOR		
	2.	Model	Manufacturer's Designation	TX-160		TX-175		
				English	Metric	English	Metric	
	3.	Capacity	Rated Capacity	lb (kg)	16,000	7,258	17,500	7,938
	4.	Load Center	Distance	in (mm)	24	610	24	610
	5.	Power Type	Gas, LPG, Or Diesel		Diesel		Diesel	
	6.	Tire Type	Cushion, Pneumatic Front / Rear		Pneumatic / Pneumatic		Pneumatic / Pneumatic	
	7.	Wheels	Number (X = Driven) Front / Rear		4X / 2		4X / 2	
DIMENSIONS	8.	Upright Lift	Standard Lift (Top Of Fork)	in (mm)	134.5	3,416	134.5	3,416
	9.	Forks	Thickness	in (mm)	2.5	64	2.5	64
	9.A		Width	in (mm)	6	152	6	152
	9.B		Length	in (mm)	48	1,219	48	1,219
	10.	Tilt Angle	Standard Upright - Forward / Backward	deg.°	10 / 10		10 / 10	
	11.	Overall Dimensions	Length To Face Of Forks	in (mm)	144	3,658	144	3,658
	12.		Width (Standard Tires)	in (mm)	82.8	2,103	82.8	2,103
	13.		Height, Standard Upright Lowered	in (mm)	109	2,769	109	2,769
	14.		Height, Standard Upright Extended	in (mm)	175	4,445	175	4,445
	15.		Height To Top Of Counterweight	in (mm)				
	16.		Height To Top Of Guard	in (mm)	107.5	2,731	107.5	2,731
	17.	Turning Radius	Minimum Outside	in (mm)	140.25	3,562	140.25	3,562
	17.A		Minimum Inside	in (mm)	12.7	323	12.7	323
	18.	Load Distance	Center Of Wheel To Face Of Forks	in (mm)	24	610	24	610
	19.	Aisle Width	(Add Load Length For 90° Stacking)	in (mm)				
PERFORMANCE	20.	Stability	Comply With ANSI?		Yes		Yes	
	21.	Speeds	Travel Speed - Maximum Forward	mph (km/h)	14.8	23.8	14.8	23.8
	22.		Lift Speed - No Load	fpm (m/s)	76	.39	76	.39
	22.A		Lift Speed - With Load	fpm (m/s)	74	.38	74	.38
	23.		Lowering Speed - No Load / With Load	fpm (m/s)	Adjustable		Adjustable	
	24.	Drawbar Pull	Powershift (Maximum At Stall)	lb (kN)	14,360	64	14,360	64
25.	Gradeability	Powershift (Maximum At Stall) No Load	%	27.9		27.6		
25.A		Powershift (Maximum At Stall) With Load	%	39.8		39.5		
WEIGHT	26.	Ttl. Apprx. Wt.	Standard Truck	lb (kg)	21,500	9,752	23,000	10,433
	27.	Axle Loading	Static With Rated Load - Front	lb (kg)	34,000	15,422	36,700	16,647
	27.A		Static With Rated Load - Rear	lb (kg)	3,500	1,588	3,800	1,724
	27.B		Static With No Load - Front	lb (kg)	10,100	4,581	10,500	4,763
	27.C		Static With No Load - Rear	lb (kg)	11,400	5,171	12,500	5,670
WHEELS / TIRES	28.		Number - Front / Rear		4 / 2		4 / 2	
	29.	Tires	Size - Front		8.25 x 15 - 14 PR		8.25 x 15 - 14 PR	
	30.		Size - Rear		8.25 x 15 - 14 PR		8.25 x 15 - 14 PR	
	31.		Wheelbase	Distance	in (mm)	97	2,464	97
	32.	Tread	Center Of Outside (Dual) Tires - Front	in (mm)	73	1,854	73	1,854
	32.A		Center Of Tires - Rear	in (mm)	64.5	1,638	64.5	1,638
	33.	Ground Clearance	No Load At Lowest Point	in (mm)	8	203	8	203
	34.		No Load At Center Of Wheelbase	in (mm)	10.25	260	10.25	260
35.	Brakes	Service / Parking - Method Of Control		Foot / Hand		Foot / Hand		
36.		Service / Parking - Method Of Operation		Hyd / Spring		Hyd / Spring		
POWER UNITS / XMS	37.	Battery	Volts / Ampere Hours (1 Battery)	V/Ah	12 / 1000		12 / 1000	
	38.		Make / Model		Cummins QSB4.5-C110		Cummins QSB4.5-C110	
	39.	Internal Combustion Engine	Output - Intermittent Per SAE Standards	hp (kW)	110	82	110	82
	40.		Governed Speed - With Load	rpm	2200		2200	
	41.		Cycle / Number Of Cylinders / Displacement	cu-in (L)	4 / 4 / 275	4 / 4 / 4.5	4 / 4 / 275	4 / 4 / 4.5
	42.	Clutch	Type		Inching		Inching	
	43.	Gear Change	Type		Hand		Hand	
	44.	Transmission	Number Of Speeds - Forward / Reverse		3 / 3		3 / 3	
	45.		Type		Powershift		Powershift	
	46.	Relief Pressure	For Attachments	psi (bar)	2,000	138	2,000	138
47.		Width Across Counterweight And Front Fenders	in (mm)	83	2,108	83	2,108	
48.		Standard Fork Spread	in (mm)	60	1,524	60	1,524	
49.		Ground To Top Of Carriage	in (mm)	41.5	1,054	41.5	1,054	
50.		Load Moment	in-lbs (m-kg)	768,000	8,849	840,000	9,678	

† NOTE: Performance specifications are for trucks equipped as described on the back page of this specification sheet. Performance specifications are affected by the condition of the vehicle, its components, and the nature and condition of the operating area. If these specifications are critical, the proposed application should be discussed with your Taylor sales representative.

"Big Red" TX-160 / TX-175

Mast Dimensions (inches / millimeters)						
2-Stage ULTRA-VU Telescopic Mast	Optional Lift Height (8)*		OAHL (13)		OAGR (14)	
	English	Metric	English	Metric	English	Metric
	134.5	3,416	109	2,767	175	4,445
	158.5	4,026	121	3,073	199	5,055
	182.5	4,636	133	3,378	223	5,664
*Includes Fork Thickness	218.5	5,550	151	3,835	259	6,579

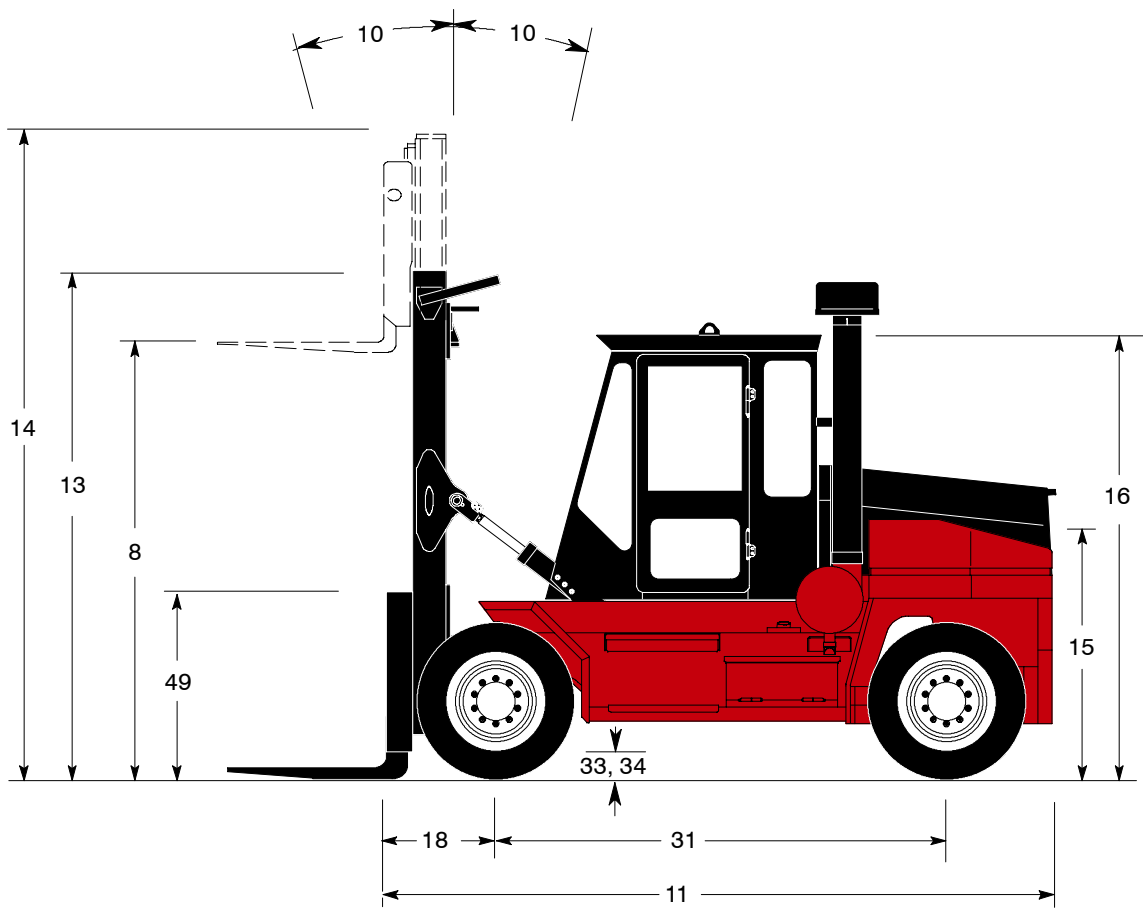
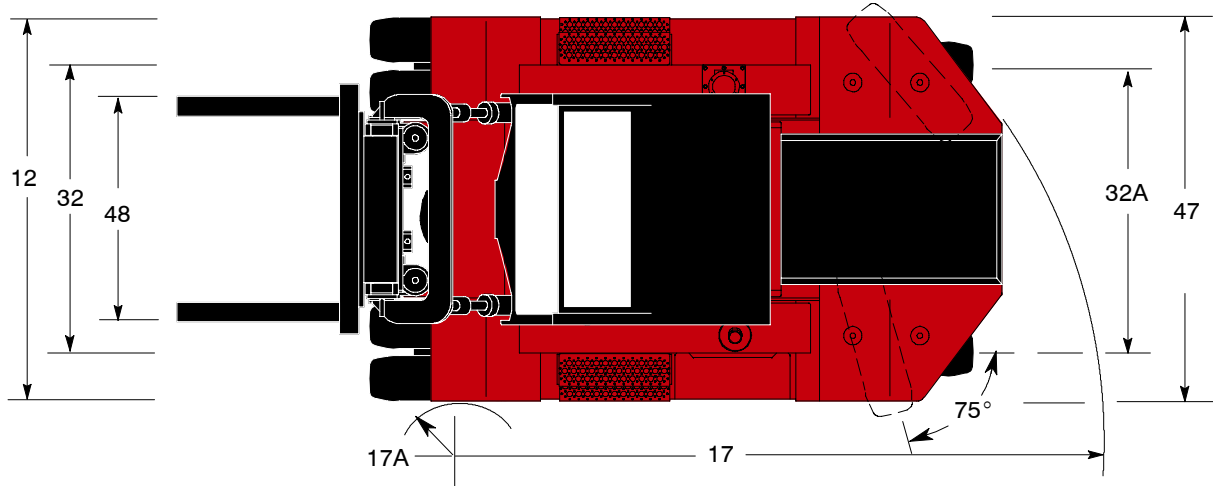

“Big Red” TX-160 / TX-175

Engine

Cummins QSB4.5-C110 electronic turbocharged, charge air aftercooled (air to air) diesel, 4-cylinder diesel engine has 275 cu-in. (4.5 L) displacement. 4.21-in. (107 mm) bore x 4.88-in. (124 mm) stroke. Rated power of 110 (82 kW) horsepower at 2200 RPM. Maximum power of 115 horsepower (86 kW) at 2000 rpm. Peak torque 360 ft.-lbs. (488 N-m) at 1500rpm. (SAE J1995 Conditions). Standard features are electronic diagnostic and maintenance monitor, fuel/water separator and engine/transmission protection systems, fuel economy, and reduced emissions. Emission certification: US EPA Tier III, Carb Tier III, EU Stage III. The fuel tank capacity is 30.5 gallons (115 L).

Air Cleaner

The dry type air cleaner has a safety element, restriction indicator, and vertical air intake extension.

Cooling System

The conventional top / bottom tank radiator has wide fin spacing to reduce dirt build-up and provide optimum engine cooling. Cooling includes engine charge air cooler, engine coolant air cooler, transmission oil air cooler, and a separate wet disc and hydraulic oil air cooler. Each can be serviced separately.

Electrical, Instrumentation, and Accessories

The one-piece instrument panel is pre-wired to accommodate heavy-duty accessories. All wiring is color and number coded.

The unit has a 12-volt electrical system with circuit breakers. Standard equipment includes a key-type anti-restart ignition switch system, 130-amp alternator, heavy-duty battery, electric fuel gauge, lighted display, electric horn, keyswitch-actuated amber strobe light, forward alarm, a reverse-actuated warning horn and 4 worklights (2 front and 2 rear).

Display indicates functions for seat belt, engine oil pressure, parking brake, battery indicator, and Tier III engine electronic diagnostic light package.

The unit has tilt steering and rear view mirrors.

All machine controls are Taylor Integrated Control Systems (TICS) using J1939 CANbus technology. This allows controllers and sensors to communicate with minimal wiring between the components. I/O modules are used to eliminate electromechanical relay devices and add reliability to the machine control system. J1939 CAN bus technology allows all machine data to be accessed through the main color display located in the cab. This display shows engine data along with warnings, and man/machine interface data. The display allows service personnel to access data needed during troubleshooting (such as sensor status and controller outputs). Machine functions can be tuned through the main display in the cab. Tuning functions are password protected to prevent operator access.

Transmission

The three-speed, fully reversing, modulated powershift transmission has inching, electric roll shift control, and a separate air-to-oil cooler. The filler pipe dipstick and large, heavy-duty oil filter are easily accessible. Automatic powershift (standard).

Drive Axle

The bolted heavy-duty planetary drive axle utilizes a hypoid ring gear and pinion. Positive rim mountings.

Steer Axle

The steer axle is a single hydraulic cylinder design with heavy-duty links from the cylinder ram directly to tapered roller bearing mounted spindles. Positive rim mountings.

Brake System

The internal force-cooled, hydraulic-actuated, wet disc, service brakes (and the hydraulic oil) are cooled by an air-to-oil cooler separate from the transmission cooler. The left pedal combines actuation of service brakes and transmission inching; the right pedal actuates the service brakes only. The parking brake control is mounted on the instrument panel.

Power Steering

The hydrostatic, steer-on-demand steering system provides constant response at all engine speeds.

Chassis

The all-welded frame has an integral counterweight. The hood slides on rollers. The cab is 2-door and includes one 40,000 BTU heater, one circulation fan, front and rear windshield wipers, front windshield washer, dome light, all glass tinted, door hold back latches with trip handles, grey insulation, and black floor mat inside cab. Cab color black only. The cab can be manually tilted over for service access. The adjustable, vinyl covered air suspension seat with arm rest and orange seat belt is standard. The seat has plus or minus 15° / 20° rotation.

Hydraulic System

The high-capacity hydraulic tank has a spin-on tank breather, wire-mesh strainers, and full-flow 10-micron return-line filters, with a replaceable element in the tank. Tank refill capacity is 25 gallons (95 L).

The hydraulic system utilizes a gear-type pump and sectional control valves. A tilt-lock valve reduces mast drift and torsional stress. The lift cylinders have self-adjusting packing. The standard joystick control lever is armrest mounted with multiple adjustments for operator comfort.

Mast, Carriage, and Rollers

The 11-ft. (3.4 m) ULTRA-VU mast provides outstanding forward vision through the mast assembly. Two double-acting lift cylinders are located behind the mast beams. Tilt cylinders are double-acting with anti-cavitation feature. Lift and tilt cylinder rods are chrome plated and have self-adjusting packing. Tilt cylinders have adjustable ears. Lift chains are located between mast rails and are visible.

The 60-in. (1,524 mm) “C” type carriage has high strength-to-weight ratio; fully adjustable from 60-in. (1,524 mm) outside to 2-in. (51 mm) inside forks.

The mast and carriage main rollers are common and use greasable, tapered, roller bearings. Chain rollers use sealed ball bearings. Adjustable side bearings compensate for wear.

Forks

The pin-mounted forks are hammer forged from heat treated steel with increased thickness in critical heel sections. Size: 2.5-in. x 6-in. x 48-in. (64 mm x 152 mm x 1,219 mm).

This vehicle is certified to meet the applicable design and performance criteria required for Powered Industrial Trucks in OSHA Safety and Health Standards, Title 29 CFR, Part 1910.178, and the applicable design and performance requirements in ANSI B56.1 that were in effect at the time of manufacture. These standards also apply to the user and should be adhered to while operating this vehicle.

All specifications are subject to change without notice. Some operating data may be affected by the condition of the operating area. If these specifications are critical, contact the factory.

Note: Illustrations of equipment may sometimes show optional equipment not included on a standard model.