



**“Big Red”  
TX-250M**

---

**Taylor Industrial Truck  
Standard Specifications**

TX-250M Rated Capacity 25,000-lbs. (**11,350 kg**)

24-in. (**610 mm**) Load Center

121-in. (**3,074 mm**) Wheelbase

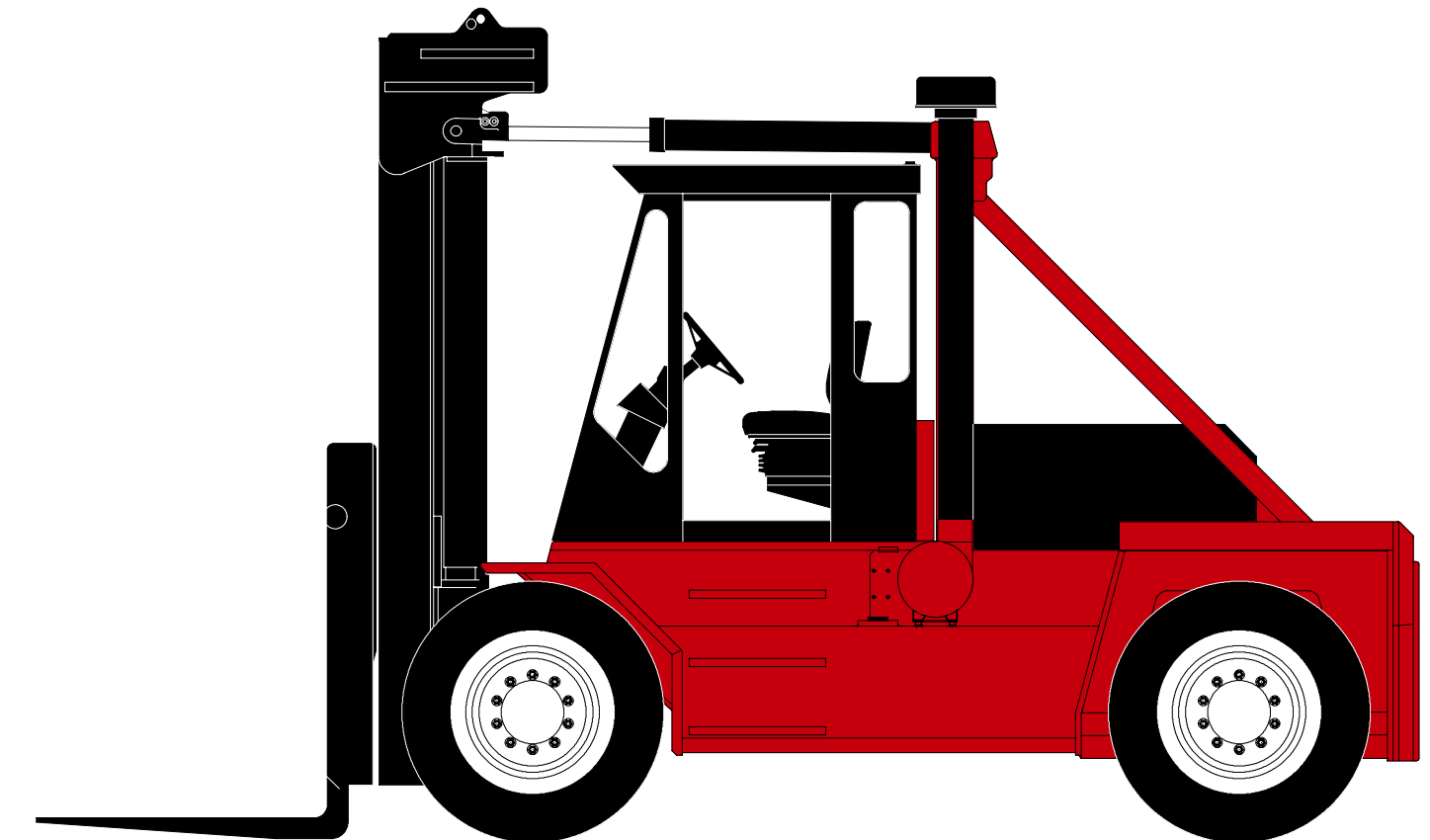

# "Big Red" TX-250M

GENERAL	1.	Manufacturer	Manufacturer's Name	TAYLOR		
	2.	Model	Manufacturer's Designation	TX-250M		
				English	Metric	
	3.	Capacity	Rated Capacity	lb (kg)	25,000 11,350	
	4.	Load Center	Distance	in (mm)	24 610	
	5.	Power Type	Gas, LPG, Or Diesel		Diesel	
	6.	Tire Type	Cushion, Pneumatic Front / Rear		Pneumatic / Pneumatic	
	7.	Wheels	Number (X = Driven) Front / Rear		4X / 2	
DIMENSIONS	8.	Upright Lift	Standard Lift (Top Of Fork)	in (mm)	134.7 3,421	
	9.	Forks	Thickness	in (mm)	2.75 70	
	9.A		Width	in (mm)	7 178	
	9.B		Length	in (mm)	48 1,219	
	10.	Tilt Angle	Standard Upright - Forward / Backward	deg.°	15 / 12	
	11.	Overall Dimensions	Length To Face Of Forks	in (mm)	182 4,623	
	12.		Width (Standard Tires)	in (mm)	101 2,565	
	13.		Height, Standard Upright Lowered	in (mm)	138.5 3,518	
	14.		Height, Standard Upright Extended	in (mm)	204.5 5,194	
	15.		Height To Top Of Counterweight	in (mm)	55 1,397	
	16.		Height To Top Of A-Frame	in (mm)	124 3,150	
	17.	Turning Radius	Minimum Outside	in (mm)	175 4,445	
	17.A		Minimum Inside	in (mm)	16.5 419	
	18.	Load Distance	Center Of Wheel To Face Of Forks	in (mm)	29 737	
	19.	Aisle Width	(Add Load Length For 90° Stacking)	in (mm)	204 5,182	
	PERFORMANCE	20.	Stability	Comply With ANSI?		Yes
		21.	Speeds	Travel Speed - Maximum Forward	mph (km/h)	16.6 26.7
		22.		Lift Speed - No Load	fpm (m/s)	89 .45
		22.A		Lift Speed - With Load	fpm (m/s)	85 .43
23.		Lowering Speed - No Load / With Load		fpm (m/s)	94 .48	
24.		Drawbar Pull	Powershift (Maximum At Stall)	lb (kN)	28,615 127	
25.		Gradeability	Powershift (Maximum At Stall) No Load	%	36.1	
25.A	Powershift (Maximum At Stall) With Load		%	47.1		
WEIGHT	26.	Ttl. Apprx. Wt.	Standard Truck	lb (kg)	33,000 14,969	
	27.	Axle Loading	Static With Rated Load - Front	lb (kg)	53,300 24,177	
	27.A		Static With Rated Load - Rear	lb (kg)4	4,700 2,132	
	27.B		Static With No Load - Front	lb (kg)	17,350 7,878	
	27.C		Static With No Load - Rear	lb (kg)	15,650 7,099	
WHEELS / TIRES	28.	Tires	Number - Front / Rear		4 / 2	
	29.		Size - Front		10.00 x 20 - 14 PR	
	30.		Size - Rear		10.00 x 20 - 14 PR	
	31.	Wheelbase	Distance	in (mm)	121 3,074	
	32.	Tread	Center Of Outside (Dual) Tires - Front	in (mm)	88 2,235	
	32.A		Center Of Tires - Rear	in (mm)	82 2,080	
	33.	Ground Clearance	No Load At Lowest Point	in (mm)	9 230	
	34.		No Load At Center Of Wheelbase	in (mm)	12 305	
	35.	Brakes	Service / Parking - Method Of Control		Foot / Hand	
	36.		Service / Parking - Method Of Operation		Hyd / Spring	
POWER UNITS / XMSN	37.	Battery	Volts / Ampere Hours (1 Battery)	V/Ah	12 / 1150	
	38.	Internal Combustion Engine	Make / Model		Cummins QSB6.7-C160	
	39.		Output - Intermittent Per SAE Standards	hp (kW)	160 119	
	40.		Governed Speed - With Load	rpm	2200	
	41.		Cycle / Number Of Cylinders / Displacement	cu-in (L)	4 / 6 / 409 4 / 6 / 6.7	
	42.	Clutch	Type		Inching	
	43.	Gear Change	Type		Hand	
	44.	Transmission	Number Of Speeds - Forward / Reverse		3 / 3	
	45.		Type		Powershift	
	46.	Relief Pressure	For Attachments	psi (bar)	2,000 138	
47.		Width Across Counterweight And Front Fenders	in (mm)	95.5 2,426		
48.		Standard Fork Spread	in (mm)	84 2,134		
49.		Ground To Top Of Carriage	in (mm)	64 1,626		
50.		Load Moment	in-lbs (m-kg)	1,325,000 15,266		

† NOTE: Performance specifications are for trucks equipped as described on the back page of this specification sheet. Performance specifications are affected by the condition of the vehicle, its components, and the nature and condition of the operating area. If these specifications are critical, the proposed application should be discussed with your Taylor sales representative.

# “Big Red” TX-250M

Mast Dimensions (inches / millimeters)						
2-Stage ULTRA-VU Telescopic Mast	Optional Lift Height (8)*		OAHL (13)		OAGR (14)	
	English	Metric	English	Metric	English	Metric
	134.7	3,421	138.5	3,518	204.5	5,194
	158.7	4,031	150.5	3,823	228.5	5,804
	182.7	4,641	162.5	4,127	252.5	6,413
*Includes Fork Thickness	218.7	5,555	180.5	4,585	288.5	7,328

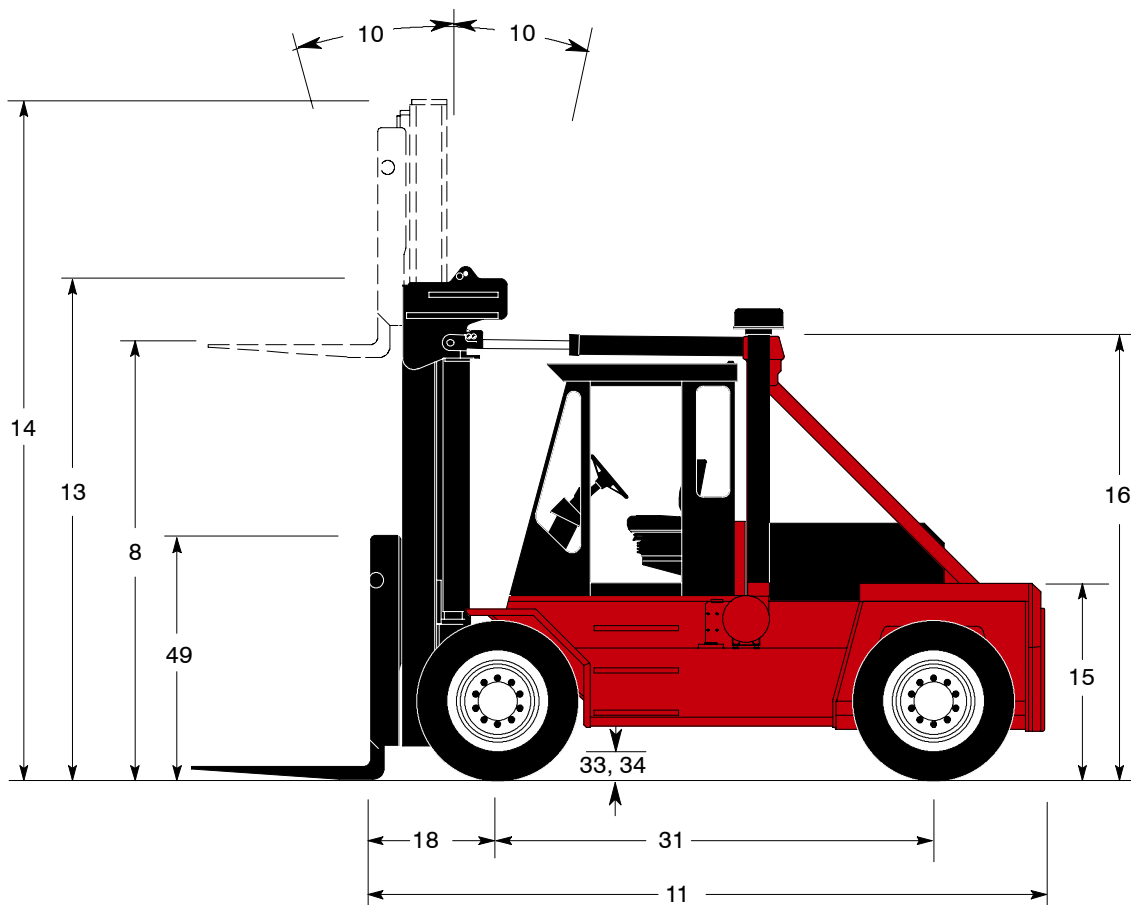
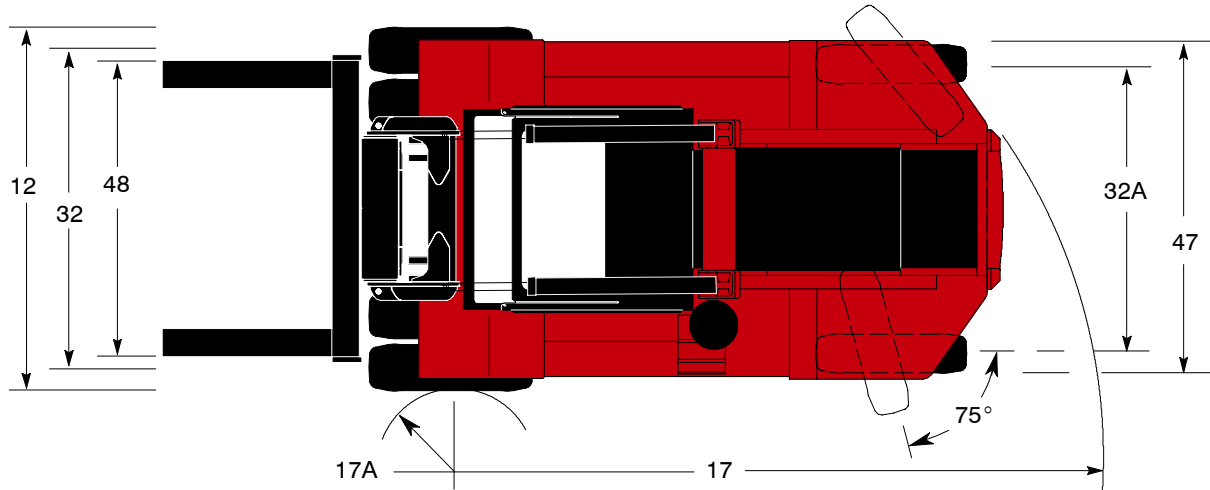

---

# “Big Red” TX-250M

## Engine

Cummins QSB6.7-C160 electronic turbocharged, charge air aftercooled (air to air) diesel, 6-cylinder diesel engine has 409 cu-in. (6.7 L) displacement. 4.09-in. (104 mm) bore x 5.2-in. (132 mm) stroke. Rated power of 160 (119 kW) horsepower at 2200 RPM. Maximum power of 165 horsepower (123 kW) at 2000 rpm. Peak torque 540 ft-lbs. (732 N-m) at 1400rpm. (SAE J1995 Conditions). Standard features are electronic diagnostic and maintenance monitor, fuel/water separator and engine/transmission protection systems, fuel economy, and reduced emissions. Emission certification: US EPA Tier III, Carb Tier III, EU Stage III.

The fuel tank capacity is 53 gallons (201 L).

## Air Cleaner

The dry type air cleaner has a safety element, restriction indicator, and vertical air intake extension.

## Cooling System

The conventional top / bottom tank radiator has wide fin spacing to reduce dirt build-up and provide optimum engine cooling. Cooling includes engine charge air cooler, engine coolant air cooler, transmission oil air cooler, and a separate wet disc and hydraulic oil air cooler. Each can be serviced separately.

## Electrical, Instrumentation, and Accessories

The one-piece instrument panel is pre-wired to accommodate heavy-duty accessories. All wiring is color and number coded.

The unit has a 12-volt electrical system with circuit breakers. Standard equipment includes a key-type anti-restart ignition switch system, 130-amp alternator, heavy-duty battery, electric fuel gauge, lighted display, electric horn, keyswitch-actuated amber strobe light, forward alarm, a reverse-actuated warning horn and 4 worklights (2 front and 2 rear).

Display indicates functions for seat belt, engine oil pressure, parking brake, battery indicator, and Tier III engine electronic diagnostic light package.

The unit has tilt steering and rear view mirrors.

All machine controls are Taylor Integrated Control Systems (TICS) using J1939 CANbus technology. This allows controllers and sensors to communicate with minimal wiring between the components. I/O modules are used to eliminate electromechanical relay devices and add reliability to the machine control system. J1939 CAN bus technology allows all machine data to be accessed through the main color display located in the cab. This display shows engine data along with warnings, and man/ machine interface data. The display allows service personnel to access data needed during troubleshooting (such as sensor status and controller outputs). Machine functions can be tuned through the main display in the cab. Tuning functions are password protected to prevent operator access.

## Transmission

The three-speed, fully reversing, modulated powershift transmission has inching, electric roll shift control, and a separate air-to-oil cooler. The filler pipe dipstick and large, heavy-duty oil filter are easily accessible. Automatic powershift (standard).

## Drive Axle

The bolted heavy-duty planetary drive axle utilizes a hypoid ring gear and pinion. Positive rim mountings.

## Steer Axle

The steer axle is a single hydraulic cylinder design with heavy-duty links from the cylinder ram directly to tapered roller bearing mounted spindles. Positive rim mountings.

## Brake System

The internal force-cooled, hydraulic-actuated, wet disc, service brakes (and the hydraulic oil) are cooled by an air-to-oil cooler separate from the transmission cooler. The left pedal combines actuation of service brakes and transmission inching; the right pedal actuates the service brakes only. The parking brake control is mounted on the instrument panel.

## Power Steering

The hydrostatic, steer-on-demand steering system provides constant response at all engine speeds.

## Chassis

The all-welded frame has an integral counterweight. The hood slides on rollers. The cab is 2-door and includes one 40,000 BTU heater, one circulation fan, front and rear windshield wipers, front windshield washer, dome light, all glass tinted, door hold back latches with trip handles, grey insulation, and black floor mat inside cab. Cab color black only. The adjustable, vinyl covered air suspension seat with arm rest and orange seat belt is standard. The seat has  $\pm 15^\circ / 20^\circ$  rotation.

## Hydraulic System

The high-capacity hydraulic tank has a spin-on tank breather, wire-mesh strainers, and full-flow 10-micron return-line filters, with a replaceable element in the tank. Tank refill capacity is 49 gallons (185 L).

The hydraulic system utilizes a gear-type pump and sectional control valves. A tilt-lock valve reduces mast drift and torsional stress. The lift cylinders have self-adjusting packing. The standard joystick control lever is armrest mounted with multiple adjustments for operator comfort.

## Mast, Carriage, and Rollers

The 11-ft. (3.4 m) ULTRA-VU telescopic, nested-channel mast, with two multiple-leaf lift chains, is constructed of high-strength steel. The double-acting lift cylinders are nested to the rear of the mast rails. Two lifting eyes and bolt-on caps permit safe, easy removal. The lift chains are nested in the mast rails and are hidden.

Pin-type 84-in. (2,134 mm) wide “C” carriage.

The mast and carriage main rollers are common and use shielded roller bearings. Chain rollers use sealed ball bearings. Side bearings are adjustable to compensate for wear.

## Forks

The forks are pin-mounted and fully adjust from the outer carriage plates to the center brace. They are forged from heat treated steel and have square tips and bottom tapers. Sizes:

Models	Thickness	Width	Length
TX-250M	2.75-in. (70 mm)	7-in. (178 mm)	48-in. (1,219 mm)

This vehicle is certified to meet the applicable design and performance criteria required for Powered Industrial Trucks in OSHA Safety and Health Standards, Title 29 CFR, Part 1910.178, and the applicable design and performance requirements in ANSI B56.1 that were in effect at the time of manufacture. These standards also apply to the user and should be adhered to while operating this vehicle.

All specifications are subject to change without notice. Some operating data may be affected by the condition of the operating area. If these specifications are critical, contact the factory.

Note: Illustrations of equipment may sometimes show optional equipment not included on a standard model.