



**“Big Red”**  
**TXB-180S / TXB-200S**

---

**Taylor Industrial Trucks**  
**Preliminary Specifications**

TXB-180S Rated Capacity 18,000-lbs. **(8,165 kg)**

TXB-200S Rated Capacity 20,000-lbs. **(9,072 kg)**

24-in. **(610 mm)** Load Center

110-in. **(2,794 mm)** Wheelbase

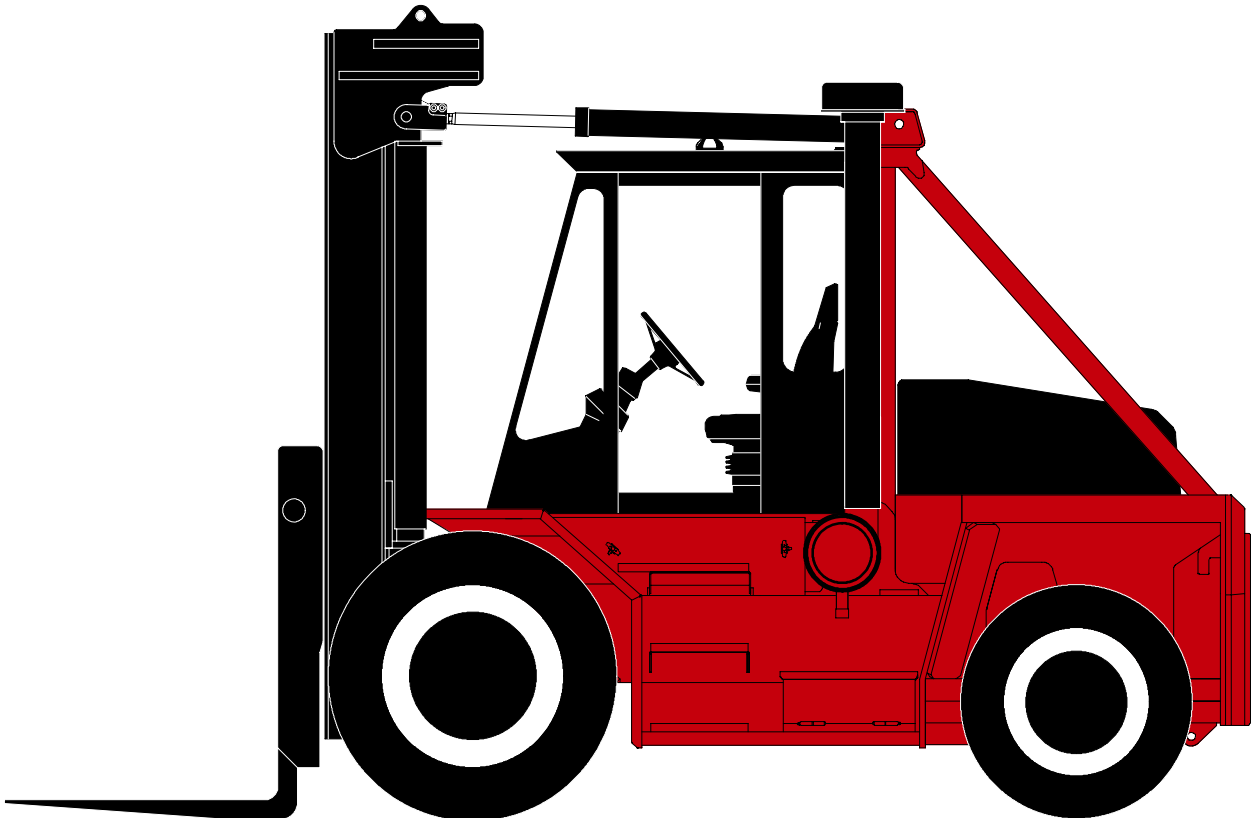

# "Big Red" TXB-180S / TXB-200S

GENERAL	1	Manufacturer	Manufacturer's Name	TAYLOR		TAYLOR			
	2	Model	Manufacturer's Designation	TXB-180S		TXB-200S			
				English	Metric	English	Metric		
	3	Capacity	Rated Capacity	lb (kg)	18,000	8,165	20,000	9,072	
	4	Load Center	Distance	in (mm)	24	610	24	610	
	5	Power Type	Gas, LPG, Or Diesel		Diesel		Diesel		
	6	Tire Type	Cushion, Pneumatic Front / Rear		Pneumatic / Pneumatic		Pneumatic / Pneumatic		
	7	Wheels	Number (X = Driven) Front / Rear		2X / 2		2X / 2		
DIMENSIONS	8	Upright Lift	Standard Lift (Top Of Fork)	in (mm)	134.5	3,416	134.7	3,421	
	9	Forks	Thickness	in (mm)	2.5	64	2.75	70	
	9A		Width	in (mm)	7	178	7	178	
	9B		Length	in (mm)	48	1,219	48	1,219	
	10	Tilt Angle	Standard Upright - Forward / Backward	deg.°	15 / 12		15 / 12		
	11	Overall Dimensions	Length To Face Of Forks	in (mm)	180.5	4,585	180.5	4,585	
	12		Width (Standard Tires)	in (mm)	99	2,515	99	2,515	
	12A		Width (Drive Axle)	in (mm)	96.75	2,457	96.75	2,457	
	13		Height, Standard Upright Lowered	in (mm)	139.5	3,543	139.5	3,543	
	14		Height, Standard Upright Extended	in (mm)	205.5	5,220	205.5	5,220	
	15		Height To Top Of Counterweight	in (mm)					
	16		Height To Top Of A-Frame	in (mm)	129.25	3,283	129.25	3,283	
	17	Turning Radius	Minimum Outside	in (mm)	162.25	4,121	162.25	4,121	
	17A		Minimum Inside	in (mm)	11.675	297	11.675	297	
		18	Load Distance	Center Of Wheel To Face Of Forks	in (mm)	39	991	39	991
		19	Aisle Width	(Add Load Length For 90° Stacking)	in (mm)	200.75	5,099	200.75	5,099
	PERFORMANCE	20	Stability	Comply With ANSI?		Yes		Yes	
21		Speeds	Travel Speed - Maximum Forward	mph (km/h)	17.3	27.8	17.3	27.8	
22			Lift Speed - No Load	fpm (m/s)	84	.43	84	.43	
22A			Lift Speed - With Load	fpm (m/s)	80	.41	80	.41	
23			Lowering Speed - No Load / With Load	fpm (m/s)	85 / 90	.43 / .46	85 / 90	.43 / .46	
24		Drawbar Pull	Powershift (Maximum At Stall)	lb (kN)	27,000	120	26,900	120	
†	Gradeability	Powershift (Maximum At Stall) No Load	%	30.2		29.1			
25A		Powershift (Maximum At Stall) With Load	%	55.7		55.6			
WEIGHT	26	Ttl. Apprx. Wt.	Standard Truck	lb (kg)	33,100	15,014	35,000	15,876	
	27	Axle Loading	Static With Rated Load - Front	lb (kg)	46,700	21,183	50,000	22,680	
	27A		Static With Rated Load - Rear	lb (kg)	4,400	1,996	4,900	2,223	
	27B		Static With No Load - Front	lb (kg)	18,350	8,324	18,600	8,437	
	27C		Static With No Load - Rear	lb (kg)	14,750	6,691	16,400	7,439	
WHEELS / TIRES	28	Tires	Number - Front / Rear		2 / 2		2 / 2		
	29		Size - Front		14.00 x 25 - 14 PR		14.00 x 25 - 14 PR		
	30		Size - Rear		10.00 x 20 - 14 PR		10.00 x 20 - 14 PR		
	31	Wheelbase	Distance	in (mm)	110	2,794	110	2,794	
	32	Tread	Center Of Tires - Front	in (mm)	83.5	2,121	83.5	2,121	
	32A		Center Of Tires - Rear	in (mm)	82	2,080	82	2,080	
	33	Ground Clearance	No Load At Lowest Point	in (mm)	10	254	10	254	
	34		No Load At Center Of Wheelbase	in (mm)	13.375	340	13.375	340	
	35	Brakes	Service / Parking - Method Of Control		Foot / Hand		Foot / Hand		
	36		Service / Parking - Method Of Operation		Hyd / Spring		Hyd / Spring		
POWER UNITS / XMISSION	37	Battery	Volts / Ampere Hours (1 Battery)	V/Ah	12 / 1000		12 / 1000		
	38	Internal Combustion Engine	Make / Model		Cummins QSB6.7-C160		Cummins QSB6.7-C160		
	39		Output - Intermittent Per SAE Standards	hp (kW)	160	119	160	119	
	40		Governed Speed - With Load	rpm	2200		2200		
	41		Cycle / Number Of Cylinders / Displacement	cu-in (L)	4 / 6 / 409	4 / 6 / 6.7	4 / 6 / 409	4 / 6 / 6.7	
	42		Clutch	Type		Inching		Inching	
	43	Gear Change	Type		Hand		Hand		
	44	Transmission	Number Of Speeds - Forward / Reverse		3 / 3		3 / 3		
	45		Type		Powershift		Powershift		
	46	Relief Press.	For Attachments	psi (bar)	2,000	138	2,000	138	
47		Width Across Counterweight	in (mm)	95.5	2,426	95.5	2,426		
48		Standard Fork Spread	in (mm)	84	2,134	84	2,134		
49		Ground To Top Of Carriage	in (mm)	64.25	1,632	64.25	1,632		
50		Load Moment	in-lbs (kg-m)	1,134,000	13,065	1,260,000	14,517		

† NOTE: Performance specifications are for trucks equipped as described on the back page of this specification sheet. Performance specifications are affected by the condition of the vehicle, its components, and the nature and condition of the operating area. If these specifications are critical, the proposed application should be discussed with your Taylor sales representative.

# "Big Red" TXB-180S / TXB-200S

Mast Dimensions (inches / millimeters)								
2-Stage ULTRA-VU Telescopic Mast  *Includes Fork Thickness	Optional Lift Height (8)*				OAHL (13)		OAGR (14)	
	TXB-180S		TXB-200S		TXB-180S & TXB-200S		TXB-180S & TXB-200S	
	English	Metric	English	Metric	English	Metric	English	Metric
	134.5	3,416	134.7	3,421	139.5	3,543	205.5	5,220
	158.5	4,026	158.7	4,031	151.5	3,848	229.5	5,829
	182.5	4,636	182.7	4,641	163.5	4,153	253.5	6,439
	218.5	5,550	218.7	5,555	181.5	4,610	289.5	7,353

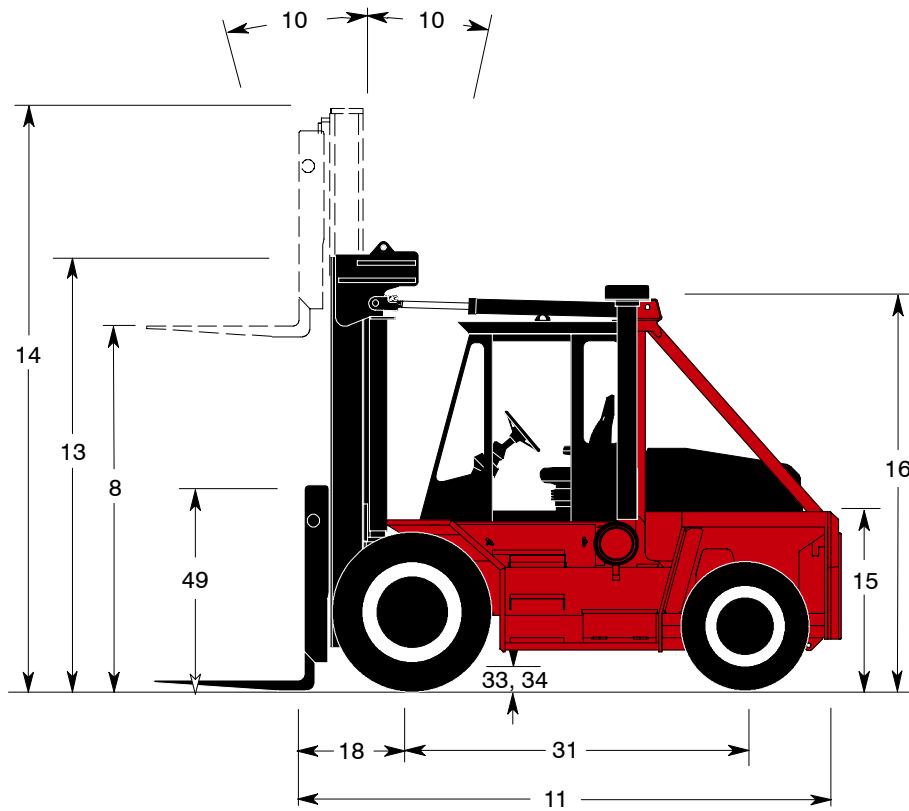
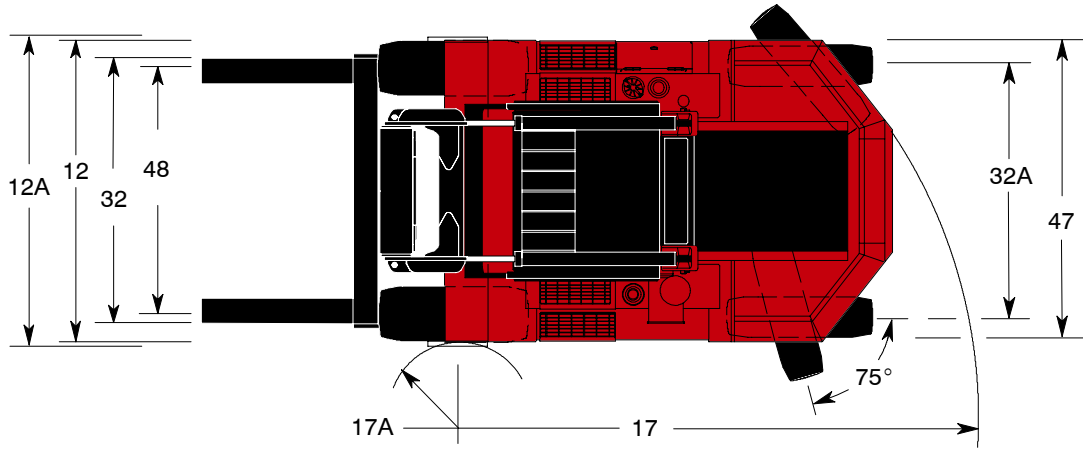

# “Big Red” TXB-180S / TXB-200S

## Engine

Cummins QSB6.7-C160 electronic turbocharged, charge air aftercooled (air to air) diesel, 6-cylinder diesel engine has 409 cu-in. (6.7 L) displacement. 4.09-in. (104 mm) bore x 5.2-in. (132 mm) stroke. Rated power of 160 (119 kW) horsepower at 2200 RPM. Maximum power of 165 horsepower (123 kW) at 2000 rpm. Peak torque 540 ft.-lbs. (732 N-m) at 1400rpm. (SAE J1995 Conditions). Standard features are electronic diagnostic and maintenance monitor, fuel/water separator and engine/transmission protection systems, fuel economy, and reduced emissions. Emission certification: US EPA Tier III, Carb Tier III, EU Stage III.

The fuel tank capacity is 58 gallons (220 L).

## Air Cleaner

The dry type air cleaner has a safety element, restriction indicator, and vertical air intake extension.

## Cooling System

The conventional top / bottom tank radiator has wide fin spacing to reduce dirt build-up and provide optimum engine cooling. Cooling includes engine charge air cooler, engine coolant air cooler, transmission oil air cooler, and a separate wet disc and hydraulic oil air cooler. Each can be serviced separately.

## Electrical, Instrumentation, and Accessories

The one-piece instrument panel is pre-wired to accommodate heavy-duty accessories. All wiring is color and number coded.

The unit has a 12-volt electrical system with circuit breakers. Standard equipment includes a key-type anti-restart ignition switch system, 130-amp alternator, heavy-duty battery, electric fuel gauge, lighted display, electric horn, keyswitch-actuated amber strobe light, forward alarm, a reverse-actuated warning horn and 4 worklights (2 front and 2 rear).

Display indicates functions for seat belt, engine oil pressure, parking brake, battery indicator, and Tier III engine electronic diagnostic light package.

The unit has tilt steering and rear view mirrors.

All machine controls are Taylor Integrated Control Systems (TICS) using J1939 CANbus technology. This allows controllers and sensors to communicate with minimal wiring between the components. I/O modules are used to eliminate electromechanical relay devices and add reliability to the machine control system. J1939 CAN bus technology allows all machine data to be accessed through the main color display located in the cab. This display shows engine data along with warnings, and man/ machine interface data. The display allows service personnel to access data needed during troubleshooting (such as sensor status and controller outputs). Machine functions can be tuned through the main display in the cab. Tuning functions are password protected to prevent operator access.

## Transmission

The three-speed, fully reversing, modulated powershift transmission has inching, electric roll shift control, and a separate air-to-oil cooler. The filler pipe dipstick and large, heavy-duty oil filter are easily accessible. Automatic powershift (standard).

## Drive Axle

The bolted heavy-duty planetary drive axle utilizes a hypoid ring gear and pinion. Positive rim mountings.

## Steer Axle

The steer axle is a single hydraulic cylinder design with heavy-duty links from the cylinder ram directly to tapered roller bearing mounted spindles. Positive rim mountings.

## Brake System

The internal force-cooled, hydraulic-actuated, wet disc, service brakes (and the hydraulic oil) are cooled by an air-to-oil cooler separate from the transmission cooler. The left pedal combines actuation of service brakes and transmission inching; the right pedal actuates the service brakes only. The parking brake control is mounted on the instrument panel.

## Power Steering

The hydrostatic, steer-on-demand steering system provides constant response at all engine speeds.

## Chassis

The all-welded frame has an integral counterweight. The hood slides on rollers. The cab is 2-door and includes one 40,000 BTU heater, one circulation fan, front and rear windshield wipers, front windshield washer, dome light, all glass tinted, door hold back latches with trip handles, grey insulation, and black floor mat inside cab. Cab color black only. The adjustable, vinyl covered air suspension seat with arm rest and orange seat belt is standard. The seat has  $\pm 15^\circ / 20^\circ$  rotation.

## Hydraulic System

The high-capacity hydraulic tank has a spin-on tank breather, wire-mesh strainers, and full-flow 10-micron return-line filters, with a replaceable element in the tank.

The hydraulic system utilizes a gear-type pump and sectional control valves. A tilt-lock valve reduces mast drift and torsional stress. The lift cylinders have self-adjusting packing. The standard joystick control lever is armrest mounted with multiple adjustments for operator comfort.

The hydraulic tank capacity is 55 gallons (208 L).

## Mast, Carriage, and Rollers

The 11-ft. (3.4 m) ULTRA-VU telescopic, nested-channel mast, with two multiple-leaf lift chains, is constructed of high-strength steel. The double-acting lift cylinders are nested to the rear of the mast rails. Two lifting eyes and bolt-on caps permit safe, easy removal. The lift chains are nested in the mast rails and are hidden.

Pin-type 84-in. (2134 mm) wide “C” carriage.

The mast and carriage main rollers are common and use shielded roller bearings. Chain rollers use sealed ball bearings. Side bearings are adjustable to compensate for wear.

## Forks

The forks are pin-mounted and fully adjust from the outer carriage plates to the center brace. They are forged from heat treated steel and have square tips and bottom tapers. Sizes:

Models	Thickness	Width	Length
TXB-180S	2.5-in. (64 mm)	7-in. (178 mm)	48-in. (1,219 mm)
TXB-200S	2.75-in. (70 mm)	7-in. (178 mm)	48-in. (1,219 mm)

This vehicle is certified to meet the applicable design and performance criteria required for Powered Industrial Trucks in OSHA Safety and Health Standards, Title 29 CFR, Part 1910.178, and the applicable design and performance requirements in ANSI B56.1 that were in effect at the time of manufacture. These standards also apply to the user and should be adhered to while operating this vehicle.

All specifications are subject to change without notice. Some operating data may be affected by the condition of the operating area. If these specifications are critical, contact the factory.

Note: Illustrations of equipment may sometimes show optional equipment not included on a standard model.